

防混蝶阀

应用

卫生级防混蝶阀广泛用于啤酒、饮料、食品制药和精细化工等领域，它最常用于隔离那些需要安全分离的物料以及单组CIP清洗，或者在阀体组件终端。（例如：CIP回程）或者CIP溶液输入到罐内（通过清洗球）。

优点

独特的外观设计、拆卸方便。蝶板的独特设计密封性更好，若有泄露的情况下可检查出泄漏并从排污口排出。阀门有手动或气动可供选择，带智能控制器或接近开关。进口的密封件有较强的耐酸、碱和耐高温的性能，永久压缩变形小。

技术参数

- ◆ 口径范围：DN50~DN100 2"~4"
- ◆ 最大产品压力：1000Kpa（10bar）
- ◆ 最小产品压力：真空
- ◆ 温度范围：-10℃至+90℃
- ◆ 供给压缩空气：最小4bar 最大8bar

材质

- ◆ 与物料接触部分：304或316L
- ◆ 表面处理：电解
- ◆ 密封件材料：
 标配：EPDM橡胶
 另选：硅橡胶（SILICON）、氟橡胶（FKM）

Mix proof valve

Application

Sanitary mix proof valve is widely used in beer ,beverage, food, pharm and chemical industries. It is best normally used in Isolation



those in need of safe separation material and a single set of CIP cleaning, or in the valve body assembly terminal. (for example: CIP backhaul) or CIP medium into the tank (through the cleaning ball)

Advantage

Unique design, convenient disassembly and assembly. The unique design of the disc has the better sealing, if there is leaks, which can be checked for leaks and discharged from the sewage outfall. Valve have manual and pneumatic for choice, with think top or switch for choice. Import seal has performance of strong acid, alkali and high temperature resistant, small permanent compression deformation

Technical Data

- ◆ Size range: DN50~DN100 2"~4"
- ◆ Max product pressure: 1000Kpa（10bar）
- ◆ Min product pressure: Vacuum
- ◆ Temperature range: -10℃ to +90℃
- ◆ Compress air: Min 4 bar, MAX 8 bar

Material

- ◆ Contacting the medium: 304 or 316L
- ◆ Surface: Electrical polish
- ◆ Seal: EPDM rubber, Silicon, FKM

焊式手动防混蝶阀

型号type: DFHDS-01

Welded Mix Proof Valve

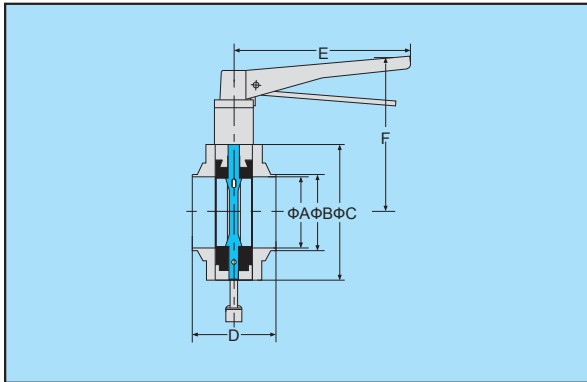

规格size	A	B	C	D	E	F	kg
DN50	49	52	110	86	175	120	
65	66	70	130	86	175	130	
80	81	85	145	89	175	140	
100	100	104	165	89	175	150	

焊式气动防混蝶阀

型号type: DFHDQ-01

Welded Pneumatic Mix Proof Valve

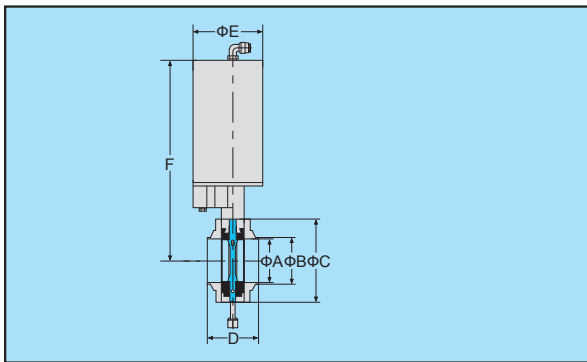

规格size	A	B	C	D	E	F	kg
DN50	49	52	110	86	85	250	
65	66	70	130	86	85	260	
80	81	85	145	89	108	290	
100	100	104	165	89	108	310	

注：信号反馈装置为可以配置选项
 Signal feed back device can be choosed or not.

焊式手动防混蝶阀

型号type: IFHDS-01

Welded Mix Proof Valve

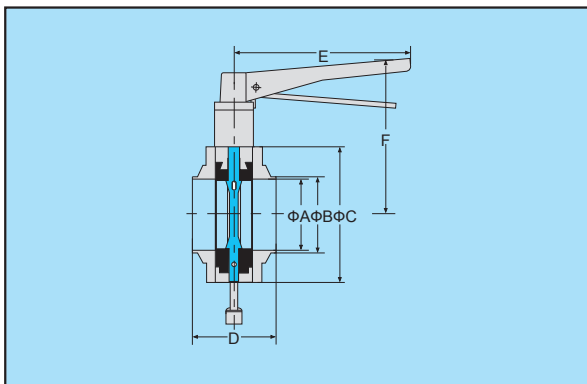

规格size	A	B	C	D	E	F	kg
2 ^s	47.8	50.8	110	86	175	120	
2.5 ^s	59.5	63.5	125	86	175	128	
3 ^s	72.1	76.1	138	89	175	137	
4 ^s	97.6	101.6	165	89	175	150	

焊式气动防混蝶阀

型号type: IFHDQ-01

Welded Pneumatic Mix Proof Valve

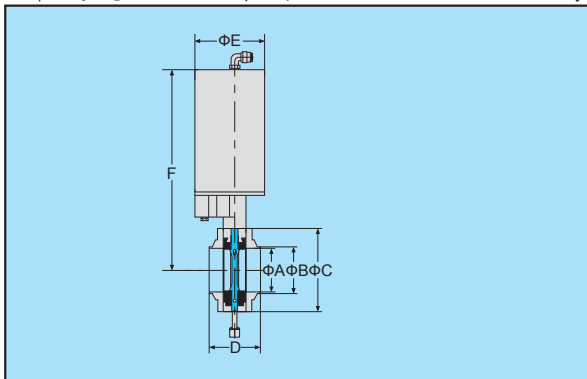

规格size	A	B	C	D	E	F	kg
2 ^s	47.8	50.8	110	86	85	250	
2.5 ^s	59.5	63.5	125	86	85	258	
3 ^s	72.1	76.1	138	89	108	287	
4 ^s	97.6	101.6	165	89	108	310	

注：信号反馈装置为可以配置选项
 Signal feed back device can be choosed or not.

样本所示管径为DIN11850第一系列尺寸，可按客户要求提供第二系列尺寸的产品。

The sizes marked in the handbook is DIN11850 NO.1 serie, No.2 serie products can also be offered by LYSF.