

截止/换向阀

优点

- ◆ 新型卫生截止/换向阀门，具有更多的安全性、洁净性、耐久性及美观性
- ◆ 拥有开放式的支架，将气动头与阀体分开，可以直接对轴密封进行检查。这一设计使阀的传动装置和产品部分分离，防止了从阀体到气动装置的热传递
- ◆ 阀门“常关闭”与“常开启”功能可瞬间转换
- ◆ 球形阀体具有理想的流动性，清洗性
- ◆ 对物料的处理更温和
- ◆ 标准的阀件设计，使联接组合有高度的灵活性和多样性
- ◆ 金属止动，保证了更长的密封寿命
- ◆ 快速、便捷的装配及维修操作

结构形式

- ◆ **F型正向单座阀**
用于管路系统中交叉处的分隔，采用单阀密封，截断两路流体。
- ◆ **C型逆向单座阀**
用于管路系统中交叉处的分隔，采用单阀密封，截断两路流体。
- ◆ **N型合流单座换向阀**
用于管路系统中流体切换，两路进一路出切换。
- ◆ **B型分流双座阀**
用于管路系统中流体切换，一路进两路出切换。



材质

- ◆ 产品与介质接触部分304或316L
- ◆ 密封材料：标配EPDM另有硅胶、氟胶可选用

表面处理

- ◆ 外部：喷砂处理 $Ra \leq 1.6\text{mm}$
抛亚光 $Ra \leq 0.6\text{mm}$
- ◆ 内部：抛 光 $Ra \leq 0.6\text{mm}$

执行器使用压缩空气质量要求

- ◆ 压缩空气连接：空气管配备空气接头R1/8"
- ◆ 最大颗粒尺寸：0.01mm
- ◆ 最大油含量：0.08ppm
- ◆ 露点：大气温度以下10℃或更低
- ◆ 最大水含量：7.5g/kg

Cut-off/Reversal Valves

Advantages

- ◆ New-style sanitary stop/reversal valves possess more improved safety, clearance, durability and appearance
- ◆ Having open supporter which separates the pneumatic actuator and valve body, check the shaft seal directly. This design separates the gearing and product parts, prevents the heat transfer from valve body to pneumatic device
- ◆ “NC” and “NO” functions can be instantly switched
- ◆ Spherical valve body has ideal fluidity and clearance
- ◆ Dealing with material becomes much milder
- ◆ Standard valve body design makes the joint style more flexible and various
- ◆ Metal stop mechanism assures the long life of the seal
- ◆ Quick, convenient assembly and maintenance operation

Structure form

- ◆ F-model positive direction single seat valve:
Used to separate the cross parts of the pipe system. It adopts single valve to seal, cutting off the two pipelines.
- ◆ C-model converse single seat valve:
Used to separate the cross parts of the pipe system. It adopts single valve to seal, cutting off the two pipelines.
- ◆ N-model concurrent single seat reversal valve:
Used to switch the liquid in the pipe system, switch the two ways enter and one way out.
- ◆ B-model diffluence double seats valve:
Used to switch the liquid in the pipe system, switch the one ways enter and two ways out.



Material

- ◆ Material Contact Parts: 304 or 316L
- ◆ Sealing material: standard EPDM Silica gel, fluorine gel for option

Surface treatment

- ◆ Outside: Sandblast $Ra \leq 1.6\text{mm}$
Sublight $Ra \leq 0.6\text{mm}$
- ◆ Inside: polish $Ra \leq 0.6\text{mm}$

Requirements For Compressed Air Quality That The Executor Needs

- ◆ Compressed air joint: air pipe equipped with air adapter R1/8"
- ◆ Max grain size: 0.01mm
- ◆ Max oil content: 0.08ppm
- ◆ Dew point: below 10°C or less
- ◆ Max water content: 7.5g/kg

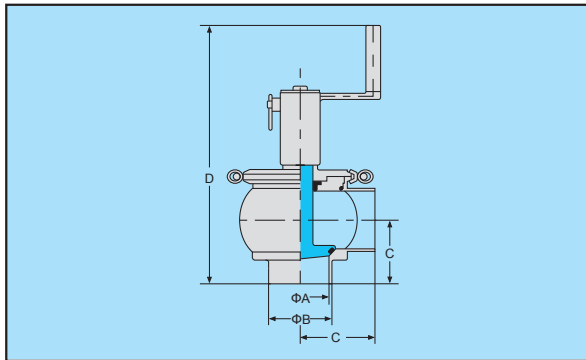
L型手动截止阀
型号type: DJS-01
L-Stop Valve

规格size	A	B	C	D	E	F	kg
DN25	25	28	60	215			
32	31	34	60	270			
40	37	40	60	275			
50	49	52	75	295			
65	66	70	100	335			
80	81	85	100	350			
100	100	104	125	360			
125	125	129	150	425			

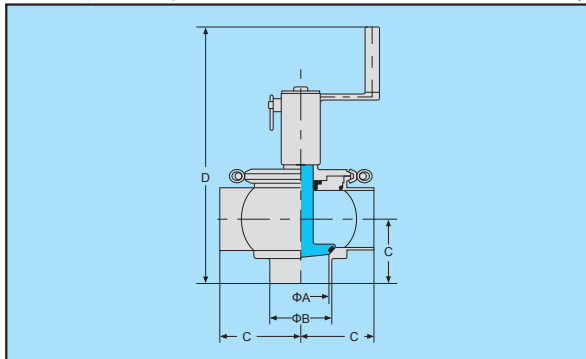
T型手动截止阀
型号type: DJS-02
T-Stop Valve

规格size	A	B	C	D	E	F	kg
DN25	25	28	60	215			
32	31	34	60	270			
40	37	40	60	275			
50	49	52	75	295			
65	66	70	100	335			
80	81	85	100	350			
100	100	104	125	360			
125	125	129	150	425			

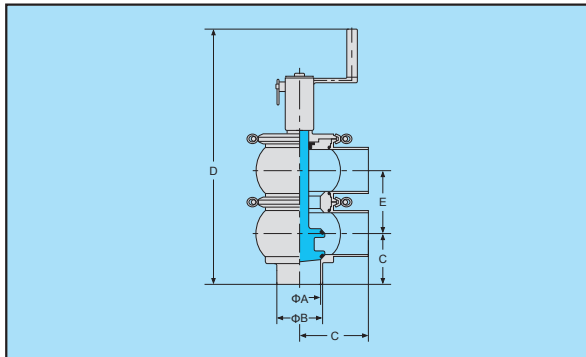
LL型手动换向阀
型号type: DJS-03
LL-Reversal Valve

规格size	A	B	C	D	E	F	kg
DN25	25	28	60	265	50		
32	31	34	60	325	55		
40	37	40	60	337	62		
50	49	52	75	368	73		
65	66	70	100	430	96		
80	81	85	100	460	111		
100	100	104	125	490	130		
125	125	129	150	580	155		

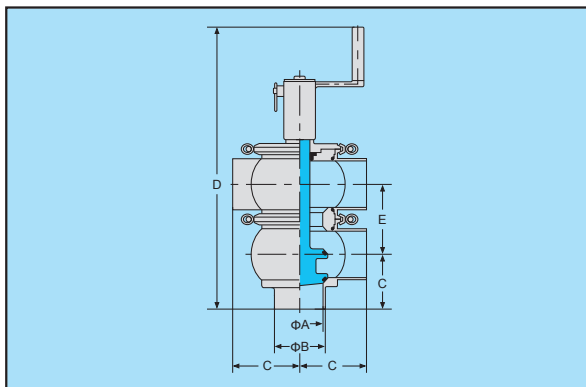
TL型手动换向阀
型号type: DJS-04
TL-Reversal Valve

规格size	A	B	C	D	E	F	kg
DN25	25	28	60	265	50		
32	31	34	60	325	55		
40	37	40	60	337	62		
50	49	52	75	368	73		
65	66	70	100	430	96		
80	81	85	100	460	111		
100	100	104	125	490	130		
125	125	129	150	580	155		

样本所示管径为DIN11850第一系列尺寸，可按客户要求提供第二系列尺寸的产品。

The sizes marked in the handbook is DIN11850 NO.1 serie, No.2 serie products can also be offered by LYSF.

LT型手动换向阀
型号type: DJS-05
LT-Reversal Valve

规格size	A	B	C	D	E	F	kg
	DN25	25	28	60	265	50	
32	31	34	60	325	55		
40	37	40	60	337	62		
50	49	52	75	368	73		
65	66	70	100	430	96		
80	81	85	100	460	111		
100	100	104	125	490	130		
125	125	129	150	580	155		

TT型手动换向阀
型号type: DJS-06
TT-Reversal Valve

规格size	A	B	C	D	E	F	kg
	DN25	25	28	60	265	50	
32	31	34	60	325	55		
40	37	40	60	337	62		
50	49	52	75	368	73		
65	66	70	100	430	96		
80	81	85	100	460	111		
100	100	104	125	490	130		
125	125	129	150	580	155		

L型手动截止阀 (短型)
型号type: DJSS-01
L-Stop Valve(short)

规格size	A	B	C	D	E	F	kg
	DN25	25	28	60	185	28.5	
32	31	34	60	242	31.5		
40	37	40	60	250	33.5		
50	49	52	75	263	42.5		
65	66	70	100	290	54		
80	81	85	100	315	63.5		
100	100	104	125	330	71		
125	125	129	150	365	88		

T型手动截止阀 (短型)
型号type: DJSS-02
T-Stop Valve(short)

规格size	A	B	C	D	E	F	kg
	DN25	25	28	60	185	28.5	
32	31	34	60	242	31.5		
40	37	40	60	250	33.5		
50	49	52	75	263	42.5		
65	66	70	100	290	54		
80	81	85	100	315	63.5		
100	100	104	125	330	71		
125	125	129	150	365	88		

样本所示管径为DIN11850第一系列尺寸, 可按客户要求提供第二系列尺寸的产品。

The sizes marked in the handbook is DIN11850 NO.1 serie, No.2 serie products can also be offered by LYSF.

LL型手动换向阀 (短型)

型号type: DJSS-03

LL-Reversal Valve(short)

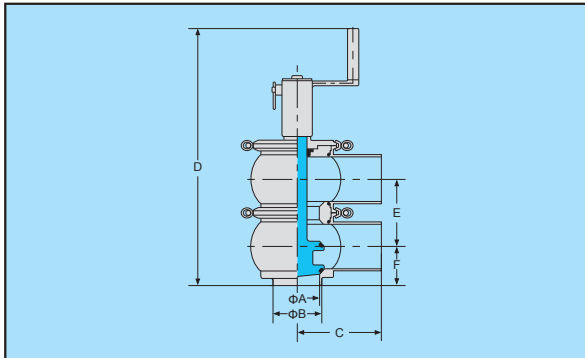

规格size	A	B	C	D	E	F	kg
DN25	25	28	60	235	50	28.5	
32	31	34	60	297	55	31.5	
40	37	40	60	312	62	33.5	
50	49	52	75	335	73	42.5	
65	66	70	100	385	96	54	
80	81	85	100	425	111	63.5	
100	100	104	125	460	130	71	
125	125	129	150	520	155	88	

TL型手动换向阀 (短型)

型号type: DJSS-04

TL-Reversal Valve(short)

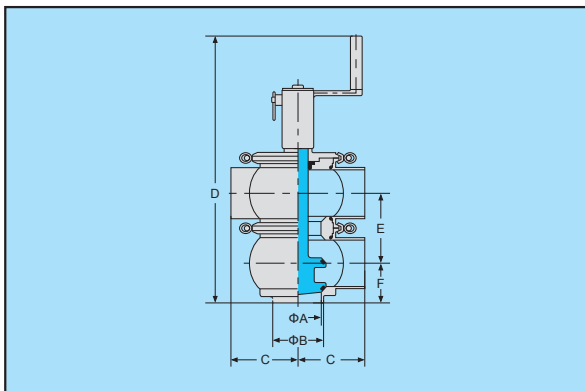

规格size	A	B	C	D	E	F	kg
DN25	25	28	60	235	50	28.5	
32	31	34	60	297	55	31.5	
40	37	40	60	312	62	33.5	
50	49	52	75	335	73	42.5	
65	66	70	100	385	96	54	
80	81	85	100	425	111	63.5	
100	100	104	125	460	130	71	
125	125	129	150	520	155	88	

LT型手动换向阀 (短型)

型号type: DJSS-05

LT-Reversal Valve(short)

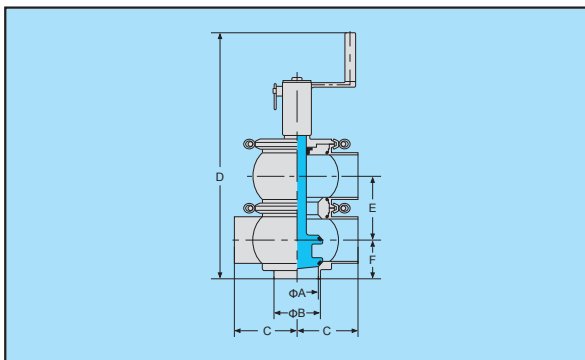

规格size	A	B	C	D	E	F	kg
DN25	25	28	60	235	50	28.5	
32	31	34	60	297	55	31.5	
40	37	40	60	312	62	33.5	
50	49	52	75	335	73	42.5	
65	66	70	100	385	96	54	
80	81	85	100	425	111	63.5	
100	100	104	125	460	130	71	
125	125	129	150	520	155	88	

TT型手动换向阀 (短型)

型号type: DJSS-06

TT-Reversal Valve(short)

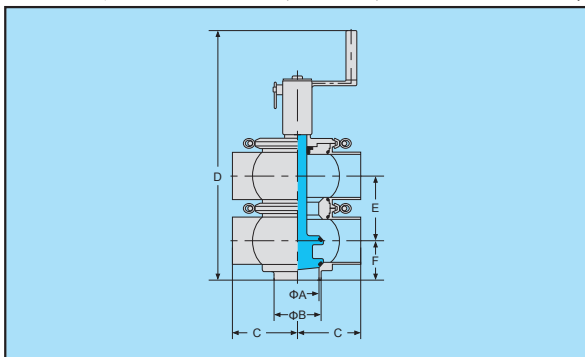

规格size	A	B	C	D	E	F	kg
DN25	25	28	60	235	50	28.5	
32	31	34	60	297	55	31.5	
40	37	40	60	312	62	33.5	
50	49	52	75	335	73	42.5	
65	66	70	100	385	96	54	
80	81	85	100	425	111	63.5	
100	100	104	125	460	130	71	
125	125	129	150	520	155	88	

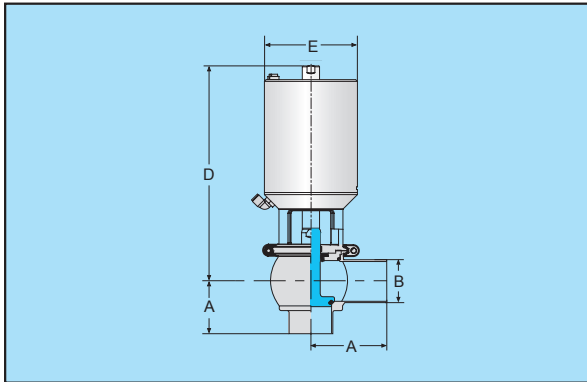
L型气动单座阀
型号type: DJF02-L
L-Pneumatic Single Seat Valve

规格size	A	B	C	D	E	F	kg
DN25	60	28		230	89		
32	60	34		235	89		
40	60	40		240	89		
50	75	52		260	109		
65	100	70		280	130		
80	100	85		310	130		
100	125	104		370	168		
125	150	129		420	204		
150	150	154		430	204		

注: 信号反馈装置为可以配置选项
 Signal feed back device can be chosen or not.

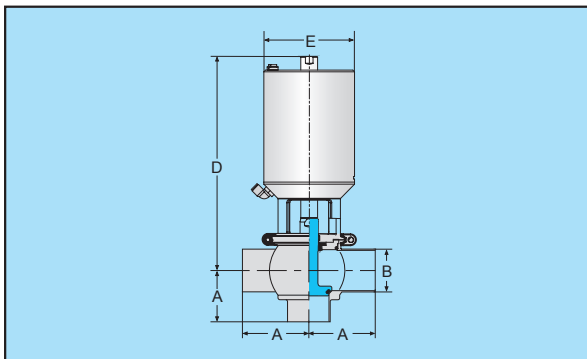
T型气动单座阀
型号type: DJF02-T
T-Pneumatic Single Seat Valve

规格size	A	B	C	D	E	F	kg
DN25	60	28		230	89		
32	60	34		235	89		
40	60	40		240	89		
50	75	52		260	109		
65	100	70		280	130		
80	100	85		310	130		
100	125	104		370	168		
125	150	129		420	204		
150	150	154		430	204		

注: 信号反馈装置为可以配置选项
 Signal feed back device can be chosen or not.

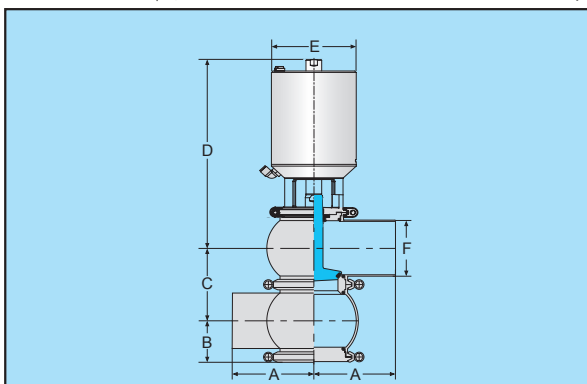
F型气动单座阀
型号type: DJF01-FA
F-Pneumatic Single Seat Valve

规格size	A	B	C	D	E	F	kg
DN25	60	20	50	230	89	28	
32	60	28	55	235	89	34	
40	60	39	62	240	89	40	
50	75	45	73	260	109	52	
65	100	55	96	280	130	70	
80	100	62	111	310	130	85	
100	125	72	130	370	168	104	
125	150	90	155	420	204	129	

注: 信号反馈装置为可以配置选项
 Signal feed back device can be chosen or not.

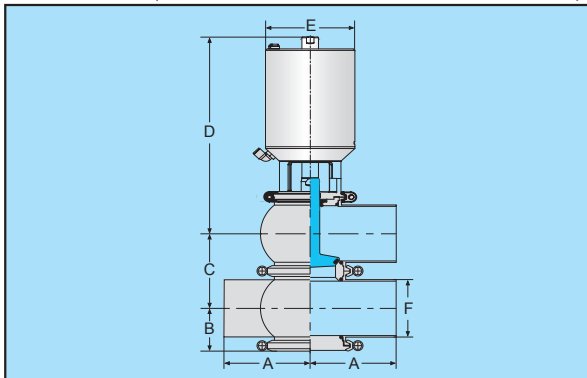
F型气动单座阀
型号type: DJF01-FB
F-Pneumatic Single Seat Valve

规格size	A	B	C	D	E	F	kg
DN25	60	20	50	230	89	28	
32	60	28	55	235	89	34	
40	60	39	62	240	89	40	
50	75	45	73	260	109	52	
65	100	55	96	280	130	70	
80	100	62	111	310	130	85	
100	125	72	130	370	168	104	
125	150	90	155	420	204	129	

注: 信号反馈装置为可以配置选项
 Signal feed back device can be chosen or not.

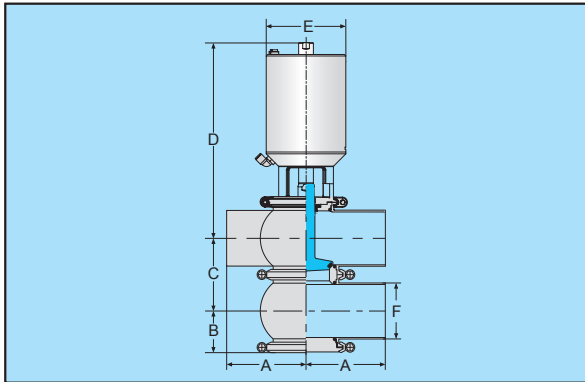
F型气动单座阀
型号type: DJF01-FC
F-Pneumatic Single Seat Valve

规格size	A	B	C	D	E	F	kg
DN25	60	20	50	230	89	28	
32	60	28	55	235	89	34	
40	60	39	62	240	89	40	
50	75	45	73	260	109	52	
65	100	55	96	280	130	70	
80	100	62	111	310	130	85	
100	125	72	130	370	168	104	
125	150	90	155	420	204	129	

注: 信号反馈装置为可以配置选项
 Signal feed back device can be chosen or not.

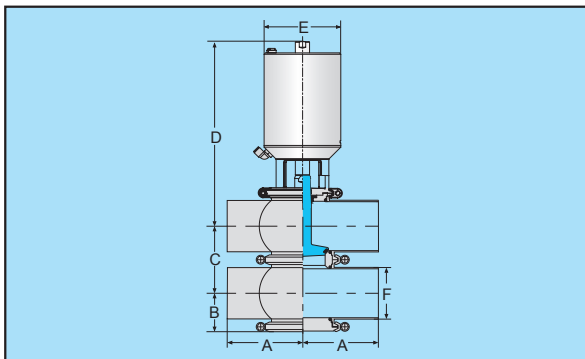
F型气动单座阀
型号type: DJF01-FE
F-Pneumatic Single Seat Valve

规格size	A	B	C	D	E	F	kg
DN25	60	20	50	230	89	28	
32	60	28	55	235	89	34	
40	60	39	62	240	89	40	
50	75	45	73	260	109	52	
65	100	55	96	280	130	70	
80	100	62	111	310	130	85	
100	125	72	130	370	168	104	
125	150	90	155	420	204	129	

注: 信号反馈装置为可以配置选项
 Signal feed back device can be chosen or not.

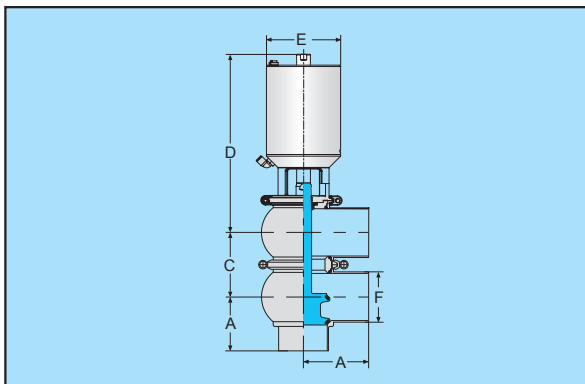
LL型气动换向阀
型号type: DJN01-NG
LL-Pneumatic Reversal Valve

规格size	A	B	C	D	E	F	kg
DN25	60		50	230	89	28	
32	60		55	235	89	34	
40	60		62	240	89	40	
50	75		73	260	109	52	
65	100		96	280	130	70	
80	100		111	310	130	85	
100	125		130	370	168	104	
125	150		155	420	204	129	

注: 信号反馈装置为可以配置选项
 Signal feed back device can be chosen or not.

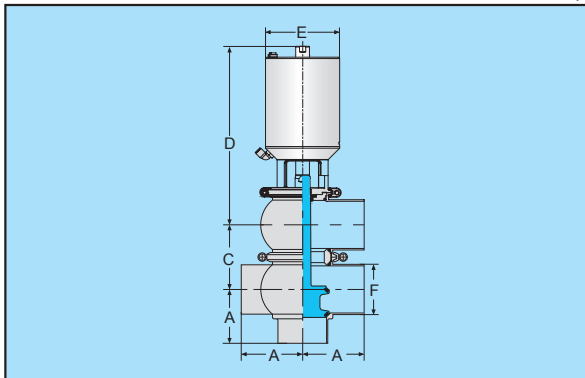
LT型气动换向阀
型号type: DJN01-NH
LT-Pneumatic Reversal Valve

规格size	A	B	C	D	E	F	kg
DN25	60		50	230	89	28	
32	60		55	235	89	34	
40	60		62	240	89	40	
50	75		73	260	109	52	
65	100		96	280	130	70	
80	100		111	310	130	85	
100	125		130	370	168	104	
125	150		155	420	204	129	

注: 信号反馈装置为可以配置选项
 Signal feed back device can be chosen or not.

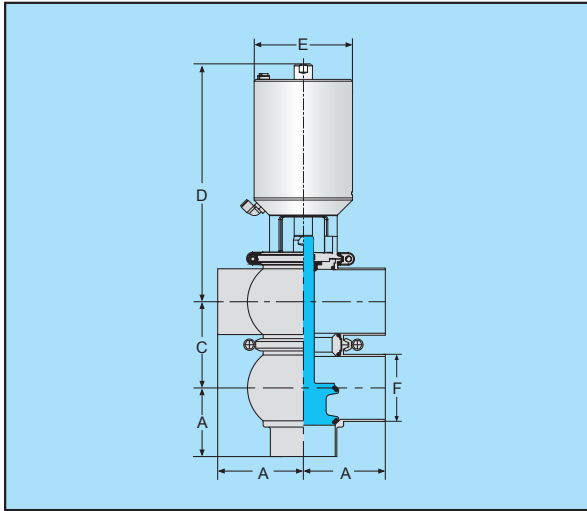
TL型气动换向阀
型号type: DJN01-NP
TL-Pneumatic Reversal Valve

规格size	A	B	C	D	E	F	kg
DN25	60		50	230	89	28	
32	60		55	235	89	34	
40	60		62	240	89	40	
50	75		73	260	109	52	
65	100		96	280	130	70	
80	100		111	310	130	85	
100	125		130	370	168	104	
125	150		155	420	204	129	

注：信号反馈装置为可以配置选项
 Signal feed back device can be choosed or not.

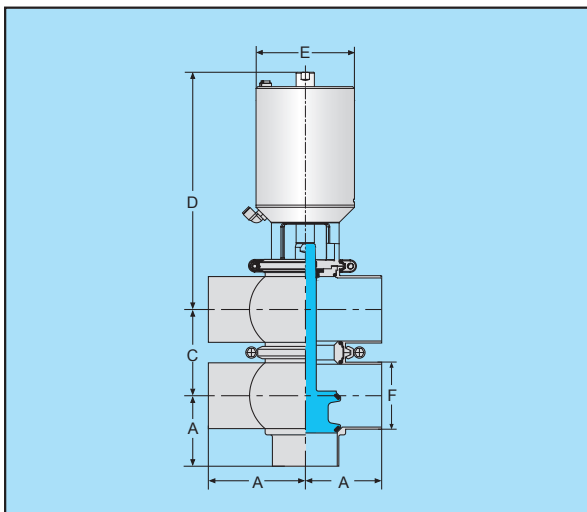
TT型气动换向阀
型号type: DJN01-NQ
TT-Pneumatic Reversal Valve

规格size	A	B	C	D	E	F	kg
DN25	60		50	230	89	28	
32	60		55	235	89	34	
40	60		62	240	89	40	
50	75		73	260	109	52	
65	100		96	280	130	70	
80	100		111	310	130	85	
100	125		130	370	168	104	
125	150		155	420	204	129	

注：信号反馈装置为可以配置选项
 Signal feed back device can be choosed or not.

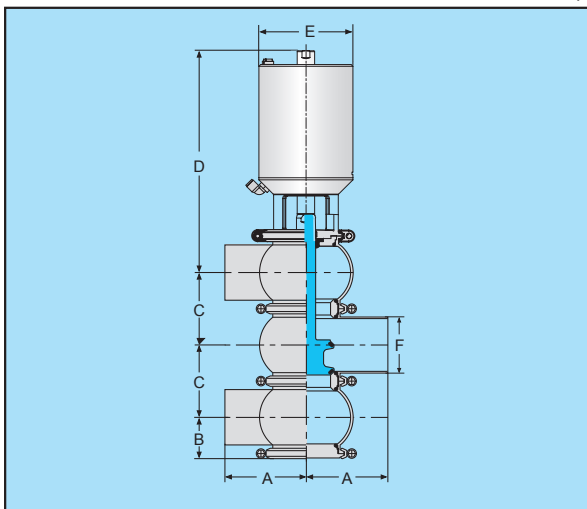
N型气动换向阀
型号type: DJN01-NJ
N-Pneumatic Reversal Valve

规格size	A	B	C	D	E	F	kg
DN25	60	20	50	230	89	28	
32	60	28	55	235	89	34	
40	60	39	62	240	89	40	
50	75	45	73	260	109	52	
65	100	55	96	280	130	70	
80	100	62	111	310	130	85	
100	125	72	130	370	168	104	
125	150	90	155	420	204	129	

注：信号反馈装置为可以配置选项
 Signal feed back device can be choosed or not.

N型气动换向阀

型号type: DJN01-NK

N-Pneumatic Reversal Valve

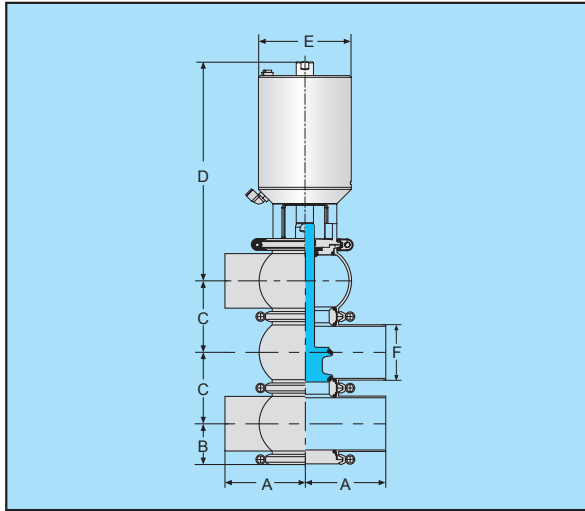

规格size	A	B	C	D	E	F	kg
DN25	60	20	50	230	89	28	
32	60	28	55	235	89	34	
40	60	39	62	240	89	40	
50	75	45	73	260	109	52	
65	100	55	96	280	130	70	
80	100	62	111	310	130	85	
100	125	72	130	370	168	104	
125	150	90	155	420	204	129	

注: 信号反馈装置为可以配置选项
Signal feed back device can be chosen or not.

N型气动换向阀

型号type: DJN01-NM

N-Pneumatic Reversal Valve

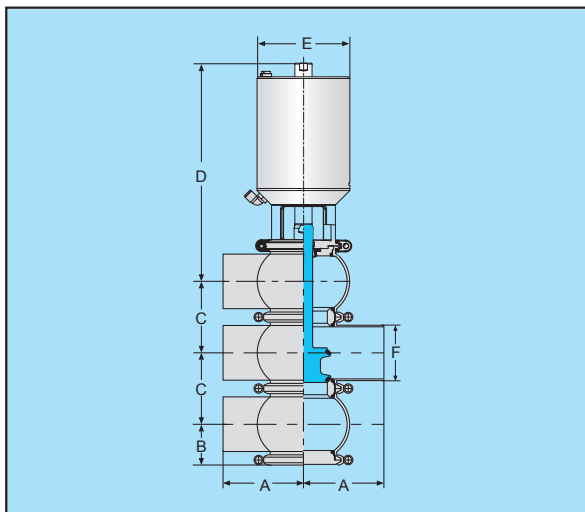

规格size	A	B	C	D	E	F	kg
DN25	60	20	50	230	89	28	
32	60	28	55	235	89	34	
40	60	39	62	240	89	40	
50	75	45	73	260	109	52	
65	100	55	96	280	130	70	
80	100	62	111	310	130	85	
100	125	72	130	370	168	104	
125	150	90	155	420	204	129	

注: 信号反馈装置为可以配置选项
Signal feed back device can be chosen or not.

N型气动换向阀

型号type: DJN01-NN

N-Pneumatic Reversal Valve

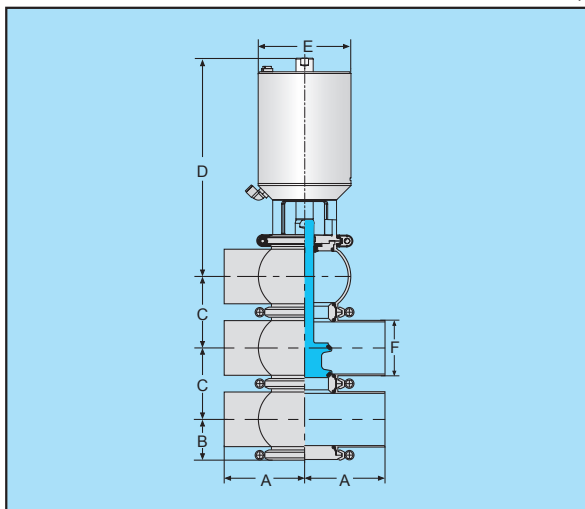

规格size	A	B	C	D	E	F	kg
DN25	60	20	50	230	89	28	
32	60	28	55	235	89	34	
40	60	39	62	240	89	40	
50	75	45	73	260	109	52	
65	100	55	96	280	130	70	
80	100	62	111	310	130	85	
100	125	72	130	370	168	104	
125	150	90	155	420	204	129	

注: 信号反馈装置为可以配置选项
Signal feed back device can be chosen or not.

N型气动换向阀

型号type: DJN01-NR

N-Pneumatic Reversal Valve

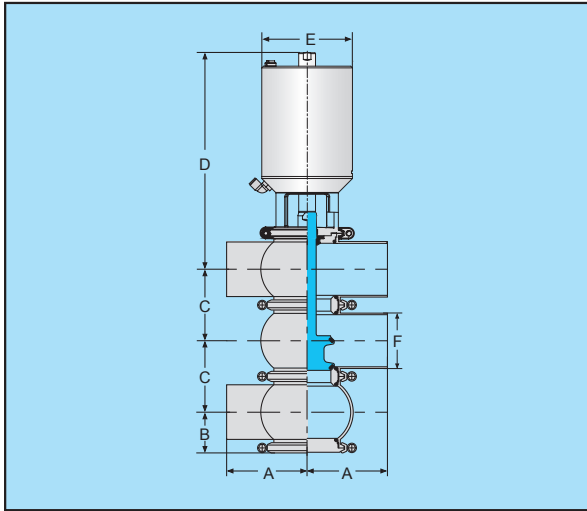

规格size	A	B	C	D	E	F	kg
DN25	60	20	50	230	89	28	
32	60	28	55	235	89	34	
40	60	39	62	240	89	40	
50	75	45	73	260	109	52	
65	100	55	96	280	130	70	
80	100	62	111	310	130	85	
100	125	72	130	370	168	104	
125	150	90	155	420	204	129	

注: 信号反馈装置为可以配置选项
 Signal feed back device can be choosed or not.

N型气动换向阀

型号type: DJN01-NS

N-Pneumatic Reversal

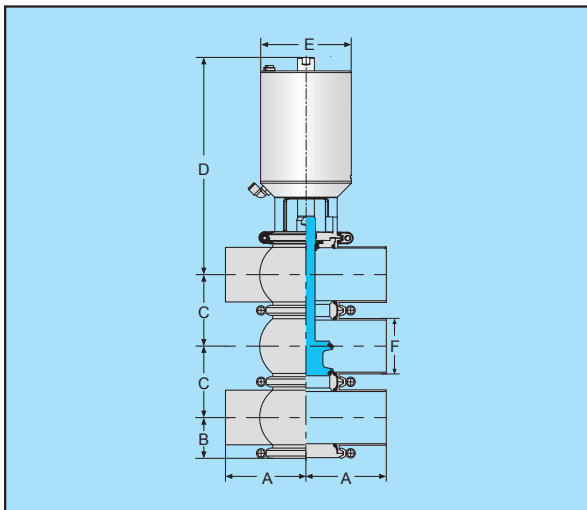

规格size	A	B	C	D	E	F	kg
DN25	60	20	50	230	89	28	
32	60	28	55	235	89	34	
40	60	39	62	240	89	40	
50	75	45	73	260	109	52	
65	100	55	96	280	130	70	
80	100	62	111	310	130	85	
100	125	72	130	370	168	104	
125	150	90	155	420	204	129	

注: 信号反馈装置为可以配置选项
 Signal feed back device can be choosed or not.

N型气动换向阀

型号type: DJN01-NU

N-Pneumatic Reversal Valve

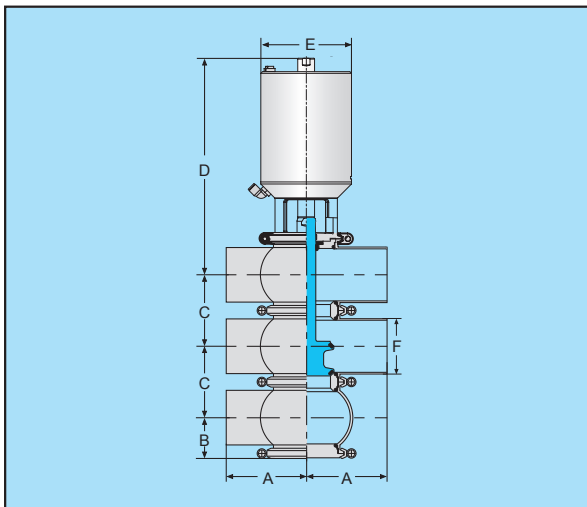

规格size	A	B	C	D	E	F	kg
DN25	60	20	50	230	89	28	
32	60	28	55	235	89	34	
40	60	39	62	240	89	40	
50	75	45	73	260	109	52	
65	100	55	96	280	130	70	
80	100	62	111	310	130	85	
100	125	72	130	370	168	104	
125	150	90	155	420	204	129	

注: 信号反馈装置为可以配置选项
 Signal feed back device can be choosed or not.

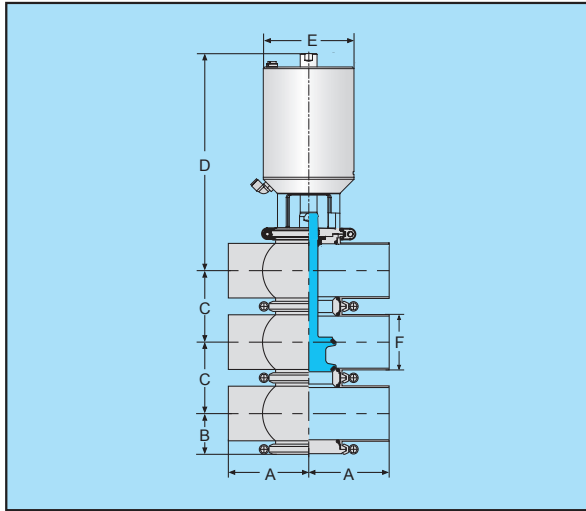
N型气动换向阀
型号type: DJN01-NV
N-Pneumatic Reversal Valve

规格size	A	B	C	D	E	F	kg
DN25	60	20	50	230	89	28	
32	60	28	55	235	89	34	
40	60	39	62	240	89	40	
50	75	45	73	260	109	52	
65	100	55	96	280	130	70	
80	100	62	111	310	130	85	
100	125	72	130	370	168	104	
125	150	90	155	420	204	129	

注: 信号反馈装置为可以配置选项
Signal feed back device can be chosen or not.

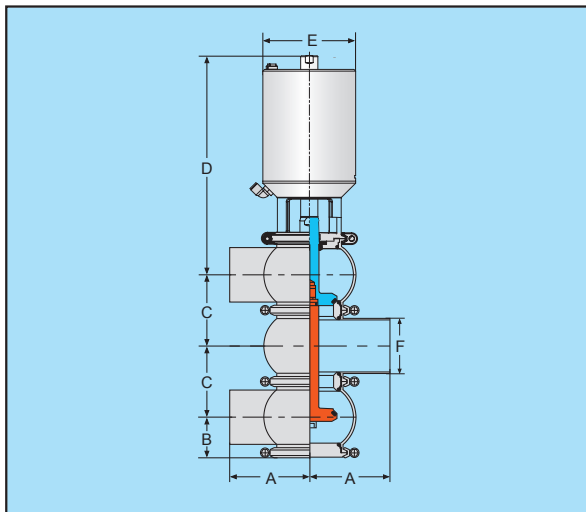
B型气动分流阀
型号type: DJB01-BJ
B-Pneumatic Shunt Valve

规格size	A	B	C	D	E	F	kg
DN25	60	20	50	230	89	28	
32	60	28	55	235	89	34	
40	60	39	62	240	89	40	
50	75	45	73	260	109	52	
65	100	55	96	280	130	70	
80	100	62	111	310	130	85	
100	125	72	130	370	168	104	
125	150	90	155	420	204	129	

注: 信号反馈装置为可以配置选项
Signal feed back device can be chosen or not.

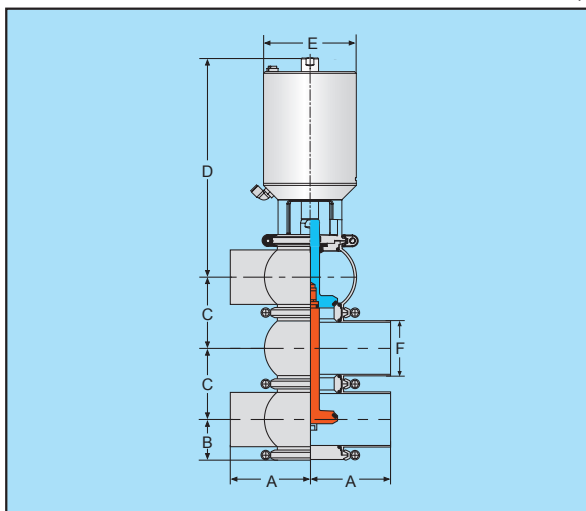
B型气动分流阀
型号type: DJB01-BK
B-Pneumatic Shunt Valve

规格size	A	B	C	D	E	F	kg
DN25	60	20	50	230	89	28	
32	60	28	55	235	89	34	
40	60	39	62	240	89	40	
50	75	45	73	260	109	52	
65	100	55	96	280	130	70	
80	100	62	111	310	130	85	
100	125	72	130	370	168	104	
125	150	90	155	420	204	129	

注: 信号反馈装置为可以配置选项
Signal feed back device can be chosen or not.

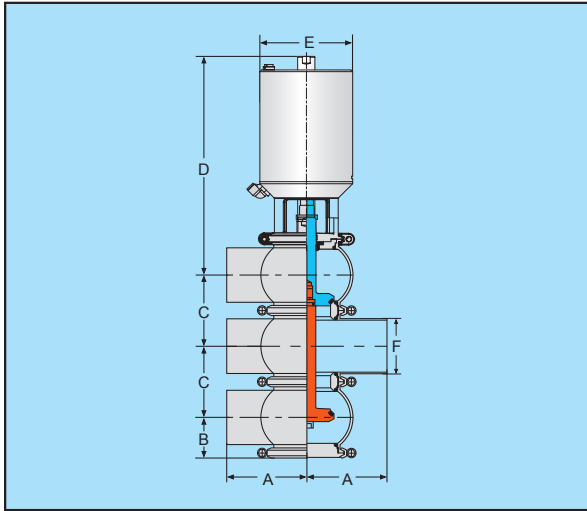
B型气动分流阀
型号type: DJB01-BM
B-Pneumatic Shunt Valve

规格size	A	B	C	D	E	F	kg
DN25	60	20	50	230	89	28	
32	60	28	55	235	89	34	
40	60	39	62	240	89	40	
50	75	45	73	260	109	52	
65	100	55	96	280	130	70	
80	100	62	111	310	130	85	
100	125	72	130	370	168	104	
125	150	90	155	420	204	129	

注：信号反馈装置为可以配置选项
 Signal feed back device can be choosed or not.

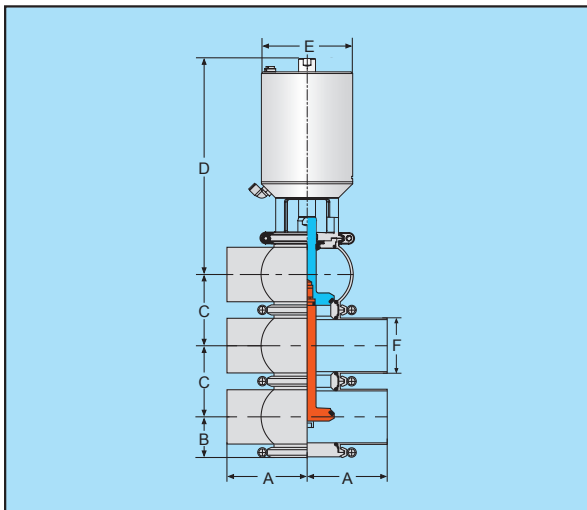
B型气动分流阀
型号type: DJB01-BN
B-Pneumatic Shunt Valve

规格size	A	B	C	D	E	F	kg
DN25	60	20	50	230	89	28	
32	60	28	55	235	89	34	
40	60	39	62	240	89	40	
50	75	45	73	260	109	52	
65	100	55	96	280	130	70	
80	100	62	111	310	130	85	
100	125	72	130	370	168	104	
125	150	90	155	420	204	129	

注：信号反馈装置为可以配置选项
 Signal feed back device can be choosed or not.

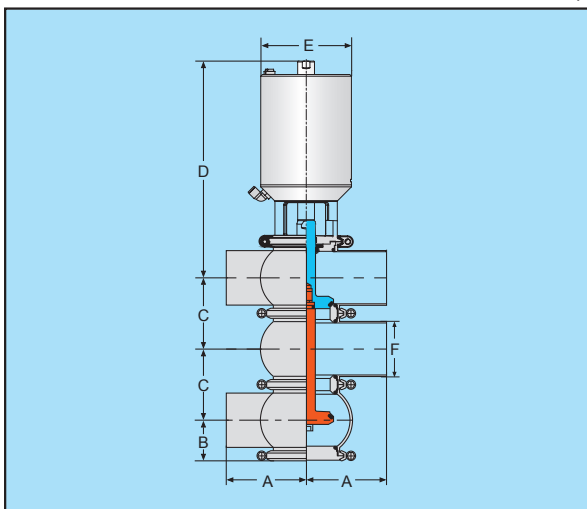
B型气动分流阀
型号type: DJB01-BR
B-Pneumatic Shunt Valve

规格size	A	B	C	D	E	F	kg
DN25	60	20	50	230	89	28	
32	60	28	55	235	89	34	
40	60	39	62	240	89	40	
50	75	45	73	260	109	52	
65	100	55	96	280	130	70	
80	100	62	111	310	130	85	
100	125	72	130	370	168	104	
125	150	90	155	420	204	129	

注：信号反馈装置为可以配置选项
 Signal feed back device can be choosed or not.

B型气动分流阀

型号type: DJB01-BS

B-Pneumatic Shunt Valve

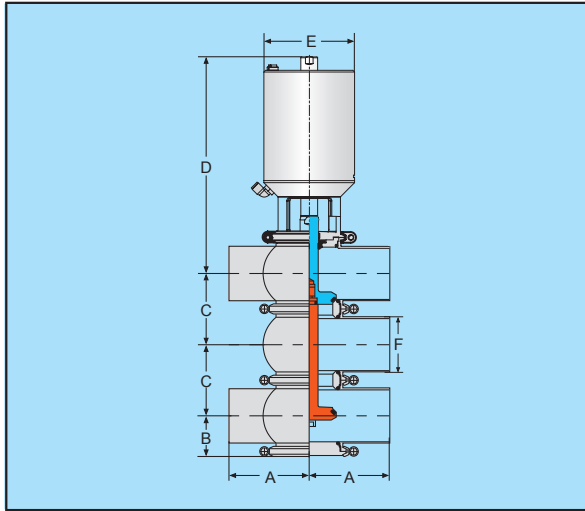

规格size	A	B	C	D	E	F	kg
DN25	60	20	50	230	89	28	
32	60	28	55	235	89	34	
40	60	39	62	240	89	40	
50	75	45	73	260	109	52	
65	100	55	96	280	130	70	
80	100	62	111	310	130	85	
100	125	72	130	370	168	104	
125	150	90	155	420	204	129	

注: 信号反馈装置为可以配置选项
 Signal feed back device can be choosed or not.

B型气动分流阀

型号type: DJB01-BU

B-Pneumatic Shunt Valve

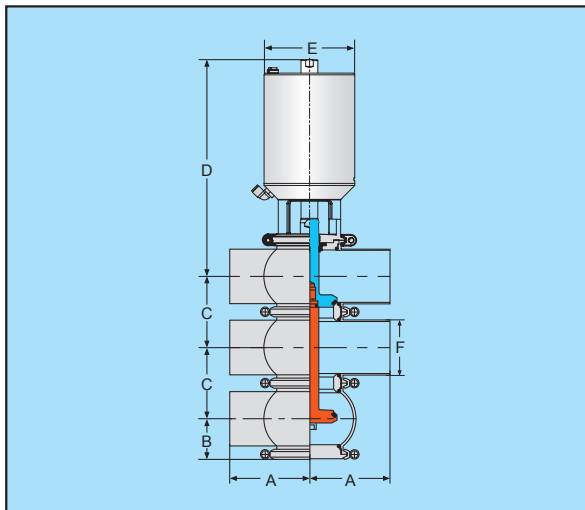

规格size	A	B	C	D	E	F	kg
DN25	60	20	50	230	89	28	
32	60	28	55	235	89	34	
40	60	39	62	240	89	40	
50	75	45	73	260	109	52	
65	100	55	96	280	130	70	
80	100	62	111	310	130	85	
100	125	72	130	370	168	104	
125	150	90	155	420	204	129	

注: 信号反馈装置为可以配置选项
 Signal feed back device can be choosed or not.

B型气动分流阀

型号type: DJB01-BV

B-Pneumatic Shunt Valve

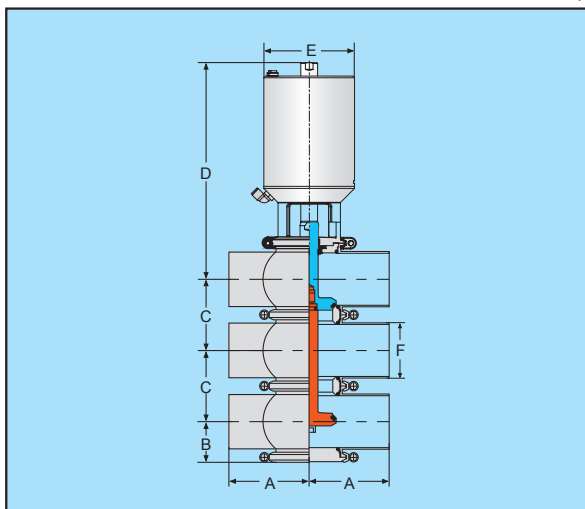

规格size	A	B	C	D	E	F	kg
DN25	60	20	50	230	89	28	
32	60	28	55	235	89	34	
40	60	39	62	240	89	40	
50	75	45	73	260	109	52	
65	100	55	96	280	130	70	
80	100	62	111	310	130	85	
100	125	72	130	370	168	104	
125	150	90	155	420	204	129	

注: 信号反馈装置为可以配置选项
 Signal feed back device can be choosed or not.

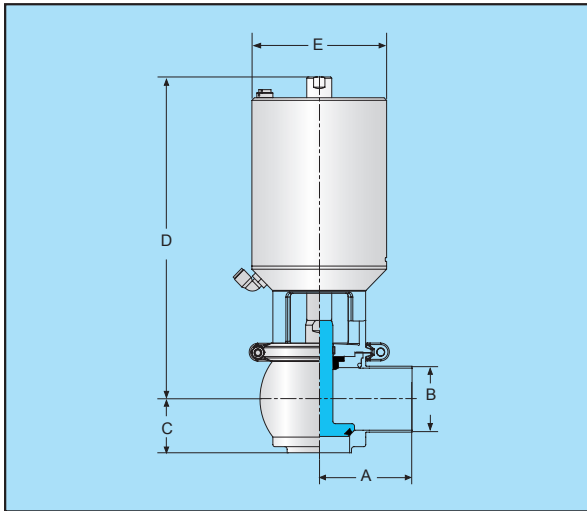
L型气动截止阀 (短型)
型号type: DJFS02-L
L-Pneumatic Single Seat Valve(short)

规格size	A	B	C	D	E	F	kg
DN25	60	28	28.5	230	89		
32	60	34	30.5	235	89		
40	60	40	33.5	240	89		
50	75	52	42.5	260	109		
65	100	70	54	280	130		
80	100	85	63.5	310	130		
100	125	104	71	370	168		
125	150	129	88	420	204		
150	150	154	100	430	204		

注: 信号反馈装置为可以配置选项
 Signal feed back device can be choosed or not.

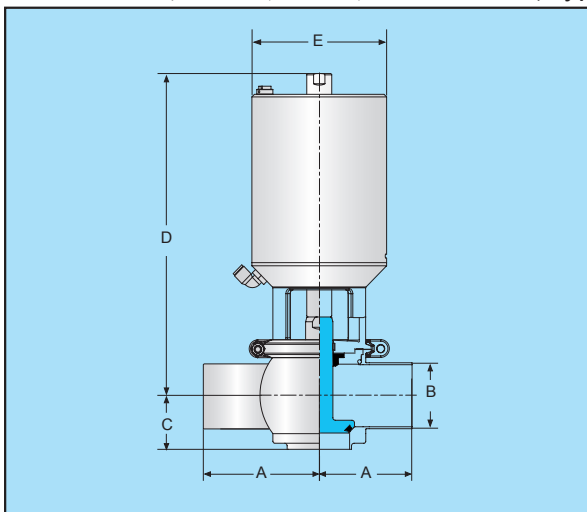
T型气动截止阀 (短型)
型号type: DJFS02-T
L-Pneumatic Single Seat Valve(short)

规格size	A	B	C	D	E	F	kg
DN25	60	28	28.5	230	89		
32	60	34	31.5	235	89		
40	60	40	33.5	240	89		
50	75	52	42.5	260	109		
65	100	70	54	280	130		
80	100	85	63.5	310	130		
100	125	104	71	370	168		
125	150	129	88	420	204		
150	150	154	100	430	204		

注: 信号反馈装置为可以配置选项
 Signal feed back device can be choosed or not.

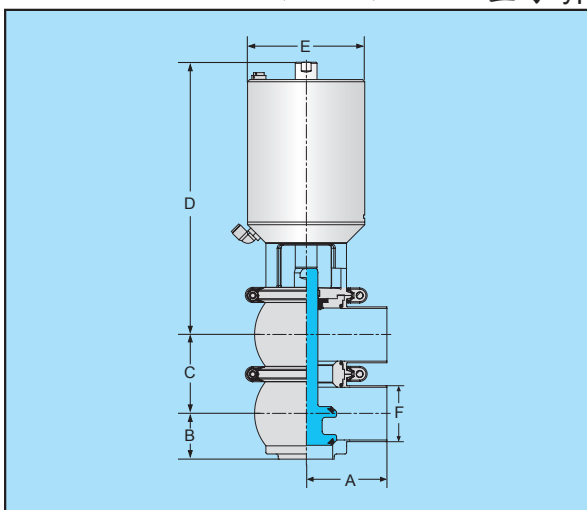
LL型气动换向阀 (短型)
型号type: DJNS01-NG
L-Pneumatic Single Seat Valve(short)

规格size	A	B	C	D	E	F	kg
DN25	60	28.5	50	230	89	28	
32	60	31.5	55	235	89	34	
40	60	33.5	62	240	89	40	
50	75	42.5	73	260	109	52	
65	100	54	96	280	130	70	
80	100	63.5	111	310	130	85	
100	125	71	130	370	168	104	
125	150	88	155	420	204	129	

注: 信号反馈装置为可以配置选项
 Signal feed back device can be choosed or not.

LT型气动换向阀 (短型)

型号type: DJNS01-NH

LT-Pneumatic Reversal Valve(short)

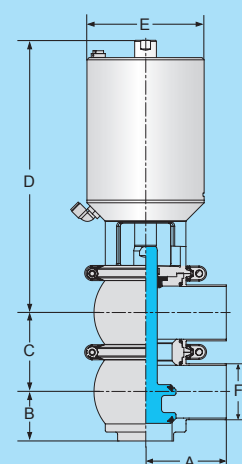

规格size	A	B	C	D	E	F	kg
DN25	60		50	230	89	28	
32	60		55	235	89	34	
40	60		62	240	89	40	
50	75		73	260	109	52	
65	100		96	280	130	70	
80	100		111	310	130	85	
100	125		130	370	168	104	
125	150		155	420	204	129	

注: 信号反馈装置为可以配置选项
Signal feed back device can be chosen or not.

TL型气动换向阀 (短型)

型号type: DJNS01-NP

TL-Pneumatic Reversal Valve(short)

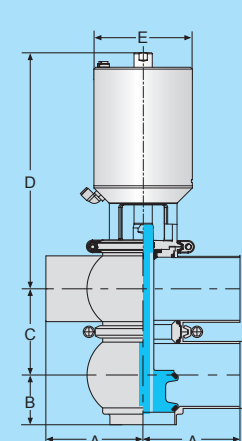

规格size	A	B	C	D	E	F	kg
DN25	60	28	50	230	89	28	
32	60	34	55	235	89	34	
40	60	40	62	240	89	40	
50	75	52	73	260	109	52	
65	100	70	96	280	130	70	
80	100	85	111	310	130	85	
100	125	104	130	370	168	104	
125	150	129	155	420	204	129	

注: 信号反馈装置为可以配置选项
Signal feed back device can be chosen or not.

TT型气动换向阀 (短型)

型号type: DJNS01-NQ

TT-Pneumatic Reversal Valve(short)

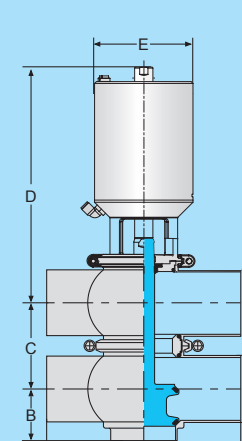

规格size	A	B	C	D	E	F	kg
DN25	60	28	50	230	89	28	
32	60	34	55	235	89	34	
40	60	40	62	240	89	40	
50	75	52	73	260	109	52	
65	100	70	96	280	130	70	
80	100	85	111	310	130	85	
100	125	104	130	370	168	104	
125	150	129	155	420	204	129	

注: 信号反馈装置为可以配置选项
Signal feed back device can be chosen or not.

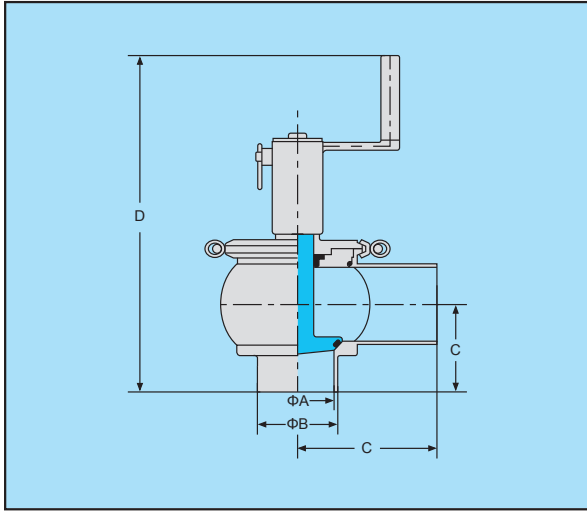
L型手动截止阀
型号type: IJSX-01
L-Stop Valve

规格size	A	B	C	D	E	F	kg
1 ^s	22.4	25.4	60	210			
1.25 ^s	29	32	60	250			
1.5 ^s	35	38	60	260			
2 ^s	48	51	75	295			
2.5 ^s	59.5	63.5	100	330			
3 ^s	72.1	76.1	100	340			
4 ^s	97.6	101.6	125	360			

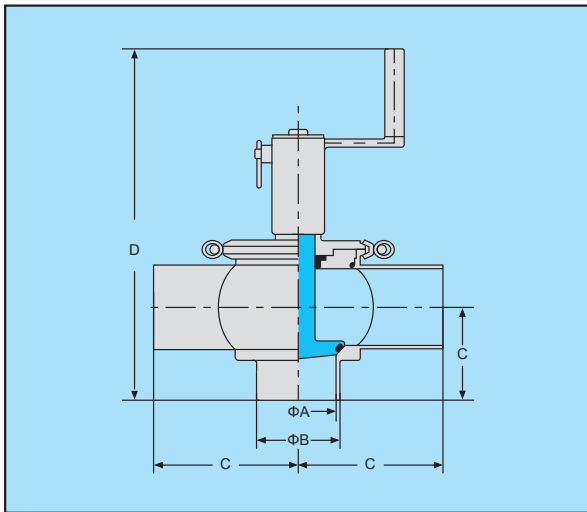
T型手动截止阀
型号type: IJSX-02
T-Stop Valve

规格size	A	B	C	D	E	F	kg
1 ^s	22.4	25.4	60	210			
1.25 ^s	29	32	60	250			
1.5 ^s	35	38	60	260			
2 ^s	48	51	75	295			
2.5 ^s	59.5	63.5	100	330			
3 ^s	72.1	76.1	100	340			
4 ^s	97.6	101.6	125	360			

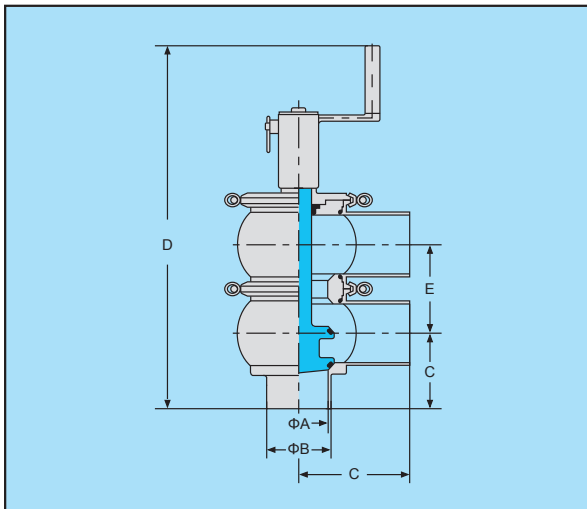
LL型手动换向阀
型号type: IJSX-03
LL-Reversal Valve

规格size	A	B	C	D	E	F	kg
1 ^s	22.4	25.4	60	260	47		
1.25 ^s	29	32	60	305	54		
1.5 ^s	35	38	60	320	59.5		
2 ^s	48	51	75	370	72		
2.5 ^s	59.5	63.5	100	420	90		
3 ^s	72.1	76.1	100	440	102		
4 ^s	97.6	101.6	125	490	128		

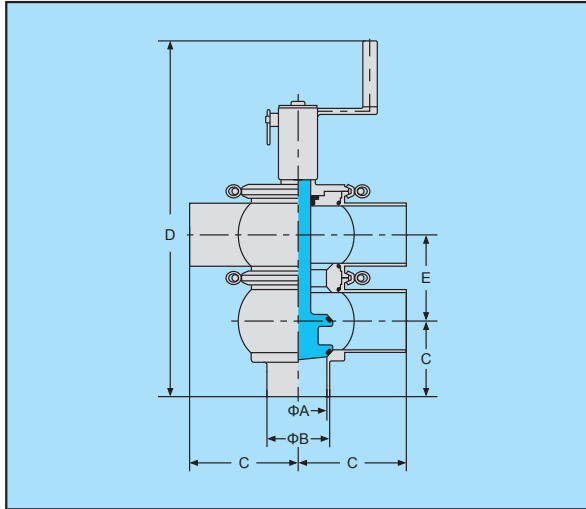
TL型手动换向阀
型号type: IJSX-04
TL-Reversal Valve

规格size	A	B	C	D	E	F	kg
1 ^s	22.4	25.4	60	260	47		
1.25 ^s	29	32	60	235	54		
1.5 ^s	35	38	60	240	59.5		
2 ^s	48	51	75	260	72		
2.5 ^s	59.5	63.5	100	280	90		
3 ^s	72.1	76.1	100	305	102		
4 ^s	97.6	101.6	125	360	128		

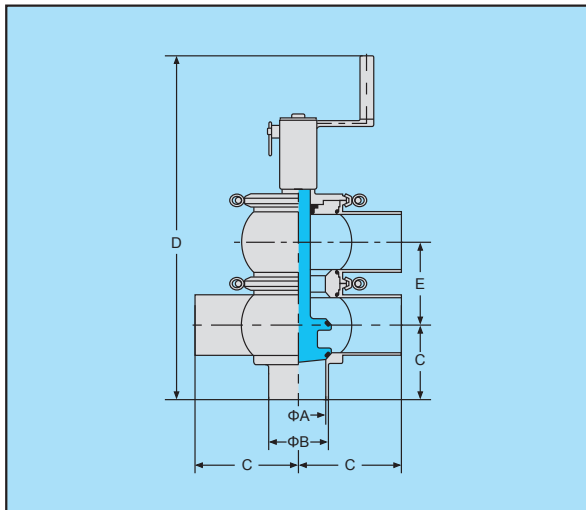
LT型手动换向阀
型号type: IJSX-05
LT-Reversal Valve

规格size	A	B	C	D	E	F	kg
1 ^s	22.4	25.4	60	260	47		
1.25 ^s	29	32	60	235	54		
1.5 ^s	35	38	60	240	59.5		
2 ^s	48	51	75	260	72		
2.5 ^s	59.5	63.5	100	280	90		
3 ^s	72.1	76.1	100	305	102		
4 ^s	97.6	101.6	125	360	128		

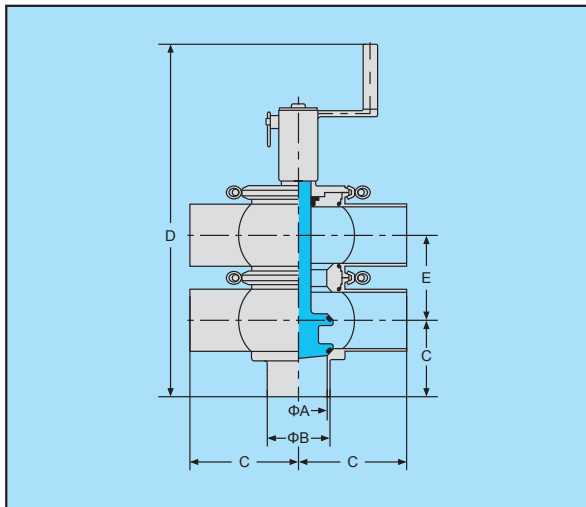
TT型手动换向阀
型号type: IJSX-06
TT-Reversal Valve

规格size	A	B	C	D	E	F	kg
1 ^s	22.4	25.4	60	260	47		
1.25 ^s	29	32	60	235	54		
1.5 ^s	35	38	60	240	59.5		
2 ^s	48	51	75	260	72		
2.5 ^s	59.5	63.5	100	280	90		
3 ^s	72.1	76.1	100	305	102		
4 ^s	97.6	101.6	125	360	128		

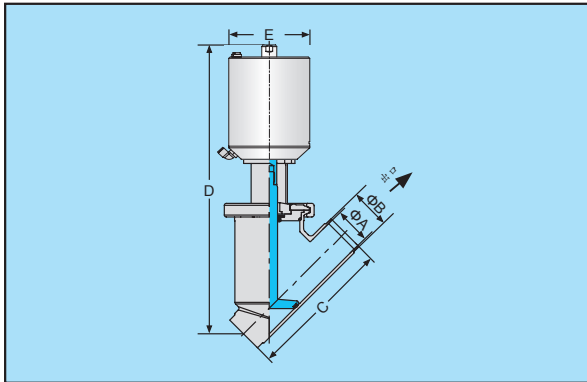
Y型气动截止阀
型号type: DJQ-07
Y-Pneumatic Stop Valve

规格size	A	B	C	D	E	F	kg
DN25	25	28	135	322	85		
32	31	34	197	363	85		
40	37	40	165	352	85		
50	49	52	190	383	108		
65	66	70	220	500	129		
80	81	85	270	534	129		
100	100	104	320	604	154		

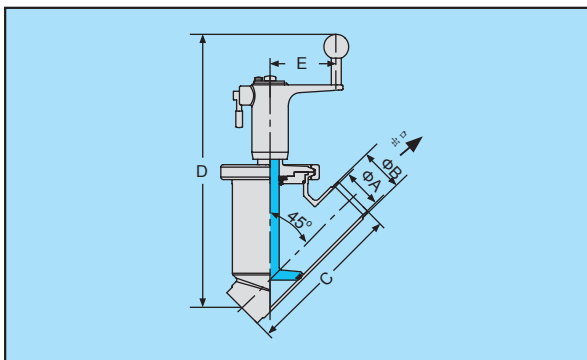
Y型手动截止阀
型号type: DJS-07
Y- Stop Valve

规格size	A	B	C	D	E	F	kg
DN25	25	28	135	287	80		
32	31	34	197	318	80		
40	37	40	165	307	80		
50	49	52	190	331	80		
65	66	70	220	409	105		
80	81	85	270	439	105		
100	100	104	320	485	105		

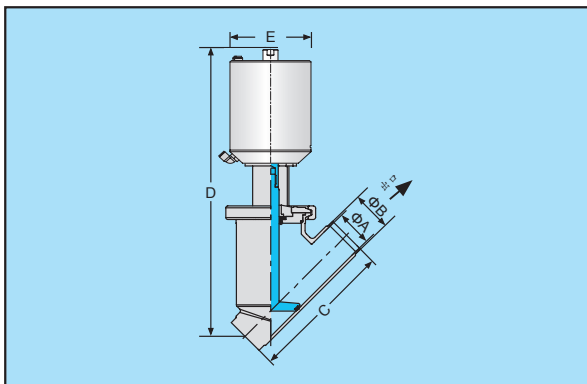
Y型气动截止阀
型号type: IJQX-07
Y-Pneumatic Stop Valve

规格size	A	B	C	D	E	F	kg
1 ^s	22.4	25.4	135	322	85		
1.5 ^s	35.1	38.1	165	352	85		
2 ^s	47.8	50.8	190	383	108		
2.5 ^s	59.5	63.5	200	467	129		
3 ^s	72.1	76.1	250	517	129		
3.5 ^s	85	89	270	534	129		
4 ^s	97.6	101.6	320	604	154		

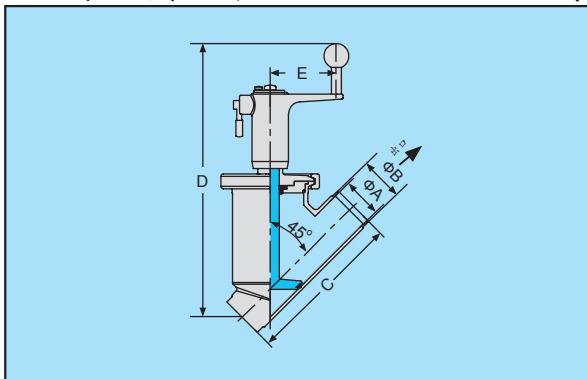
Y型手动截止阀
型号type: IJSX-07
Y-Stop Valve

规格size	A	B	C	D	E	F	kg
1 ^s	22.4	25.4	135	287	80		
1.5 ^s	35.1	38.1	165	318	80		
2 ^s	47.8	50.8	190	307	80		
2.5 ^s	59.5	63.5	200	331	80		
3 ^s	72.1	76.1	250	409	105		
3.5 ^s	85	89	270	439	105		
4 ^s	97.6	101.6	320	485	105		

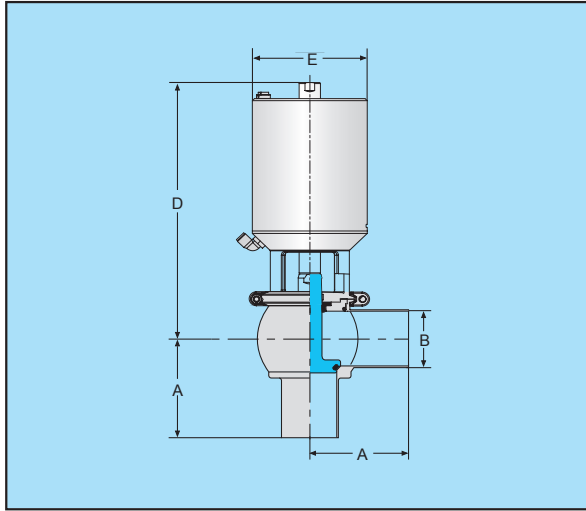
L型气动单座阀
型号type: IJQX-01
L-Pneumatic Stop Valve

规格size	A	B	C	D	E	F	kg
1 ^s	60	25.4		230	89		
1.25 ^s	60	32		235	89		
1.5 ^s	60	38		240	89		
2 ^s	75	51		260	109		
2.5 ^s	100	63.5		280	130		
3 ^s	100	76.1		305	130		
4 ^s	125	101.6		370	168		

注：信号反馈装置为可以配置选项
 Signal feed back device can be chosen or not.

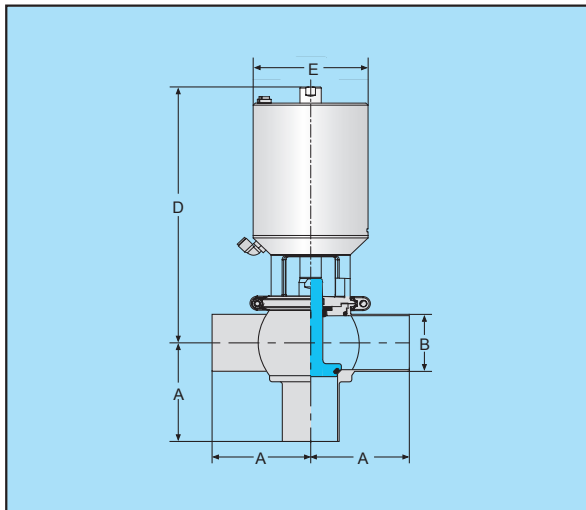
T型气动单座阀
型号type: IJQX-02
T-Pneumatic Stop Valve

规格size	A	B	C	D	E	F	kg
1 ^s	60	25.4		230	89		
1.25 ^s	60	32		235	89		
1.5 ^s	60	38		240	89		
2 ^s	75	51		260	109		
2.5 ^s	100	63.5		280	130		
3 ^s	100	76.1		305	130		
4 ^s	125	101.6		370	168		

注：信号反馈装置为可以配置选项
 Signal feed back device can be chosen or not.

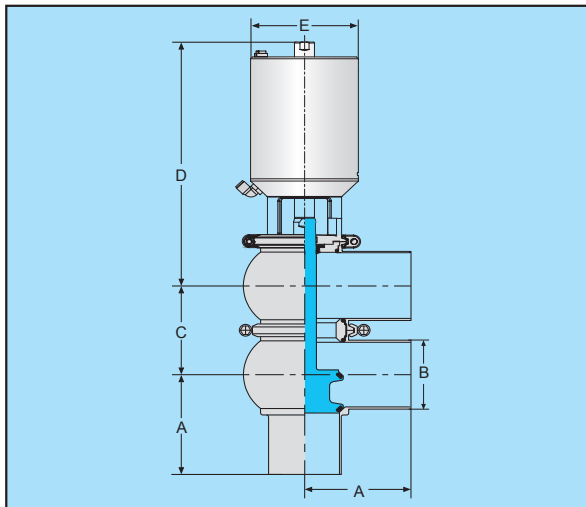
LL型气动换向阀
型号type: IJQX-03
LL-Pneumatic Reversal Valve

规格size	A	B	C	D	E	F	kg
1 ^s	60	25.4	47	230	89		
1.25 ^s	60	32	54	235	89		
1.5 ^s	60	38	59.5	240	89		
2 ^s	75	51	72	260	109		
2.5 ^s	100	63.5	90	280	130		
3 ^s	100	76.1	102	305	130		
4 ^s	125	101.6	128	370	168		

注：信号反馈装置为可以配置选项
 Signal feed back device can be chosen or not.

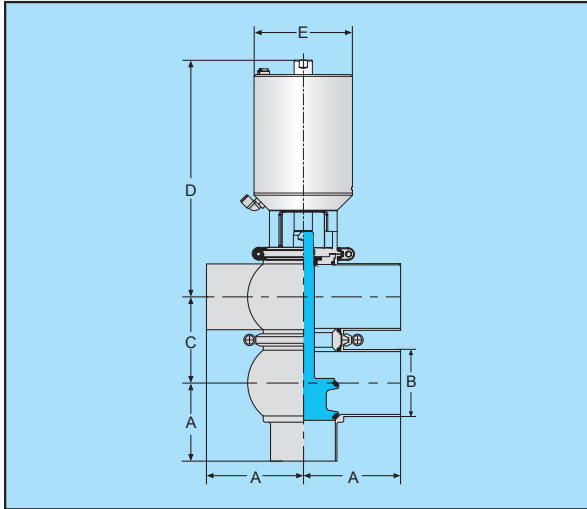
TL型气动换向阀
型号type: IJQX-04
TL-Pneumatic Reversal Valve

规格size	A	B	C	D	E	F	kg
1 ^s	60	25.4	47	230	89		
1.25 ^s	60	32	54	235	89		
1.5 ^s	60	38	59.5	240	89		
2 ^s	75	51	72	260	109		
2.5 ^s	100	63.5	90	280	130		
3 ^s	100	76.1	102	305	130		
4 ^s	125	101.6	128	370	168		

注：信号反馈装置为可以配置选项
 Signal feed back device can be chosen or not.

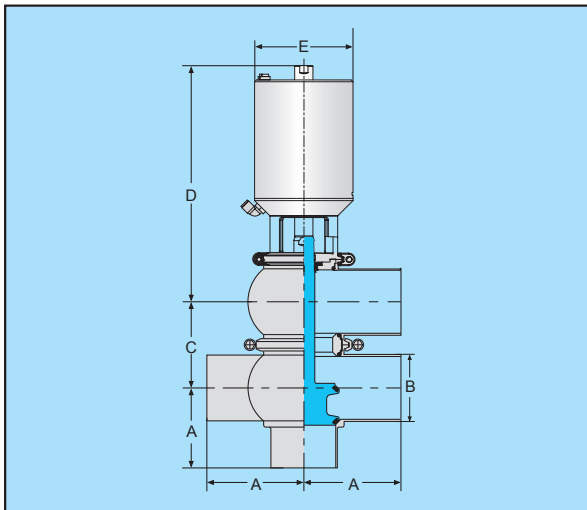
LT型气动换向阀
型号type: IJQX-05
LT-Pneumatic Reversal Valve

规格size	A	B	C	D	E	F	kg
1 ^s	60	25.4	47	230	89		
1.25 ^s	60	32	54	235	89		
1.5 ^s	60	38	59.5	240	89		
2 ^s	75	51	72	260	109		
2.5 ^s	100	63.5	90	280	130		
3 ^s	100	76.1	102	305	130		
4 ^s	125	101.6	128	370	168		

注：信号反馈装置为可以配置选项
 Signal feed back device can be chosen or not.

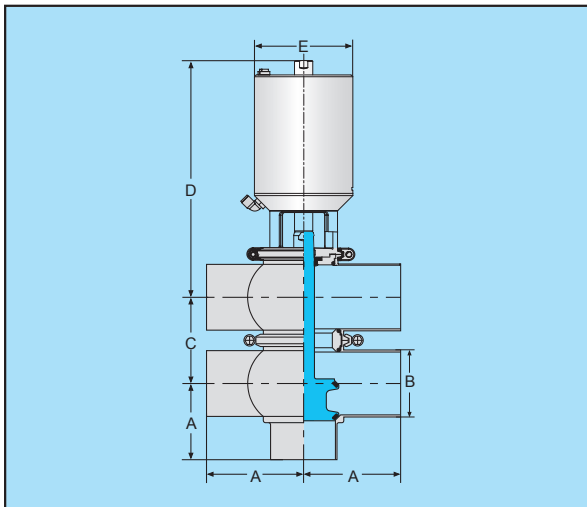
TT型气动换向阀
型号type: IJQX-06
TT-Pneumatic Reversal Valve

规格size	A	B	C	D	E	F	kg
1 ^s	60	25.4	47	230	89		
1.25 ^s	60	32	54	235	89		
1.5 ^s	60	38	59.5	240	89		
2 ^s	75	51	72	260	109		
2.5 ^s	100	63.5	90	280	130		
3 ^s	100	76.1	102	305	130		
4 ^s	125	101.6	128	370	168		

注：信号反馈装置为可以配置选项
 Signal feed back device can be chosen or not.

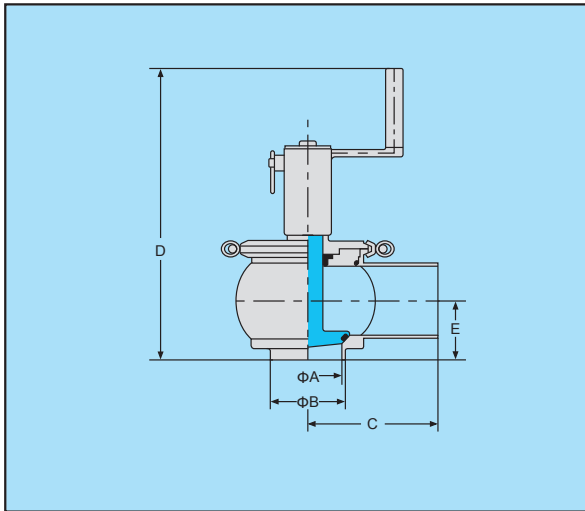
L型手动截止阀 (短型)
型号type: IJSS-01
L-Stop Valve(short)

规格size	A	B	C	D	E	F	kg
1 ^s	22.4	25.4	60	180	28		
1.25 ^s	29	32	60	220	30.5		
1.5 ^s	35	38	60	234	33.5		
2 ^s	48	51	75	263	43		
2.5 ^s	59.5	63.5	100	280	50.5		
3 ^s	72.1	76.1	100	300	57		
4 ^s	97.6	101.6	125	325	71		

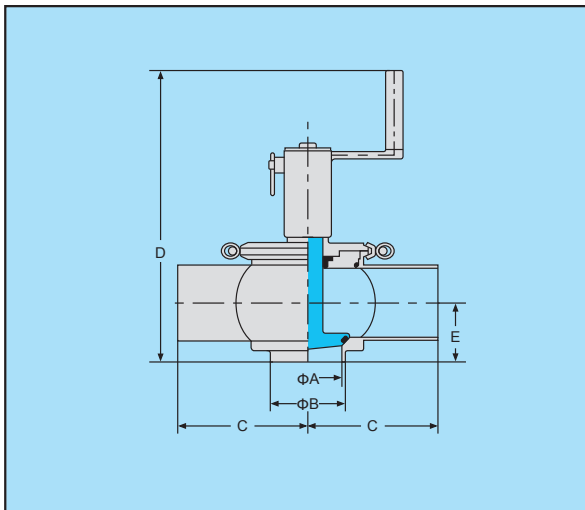
T型手动截止阀 (短型)
型号type: IJSS-02
T-Stop Valve(short)

规格size	A	B	C	D	E	F	kg
1 ^s	22.4	25.4	60	180	28		
1.25 ^s	29	32	60	220	30.5		
1.5 ^s	35	38	60	234	33.5		
2 ^s	48	51	75	263	43		
2.5 ^s	59.5	63.5	100	280	50.5		
3 ^s	72.1	76.1	100	300	57		
4 ^s	97.6	101.6	125	325	71		

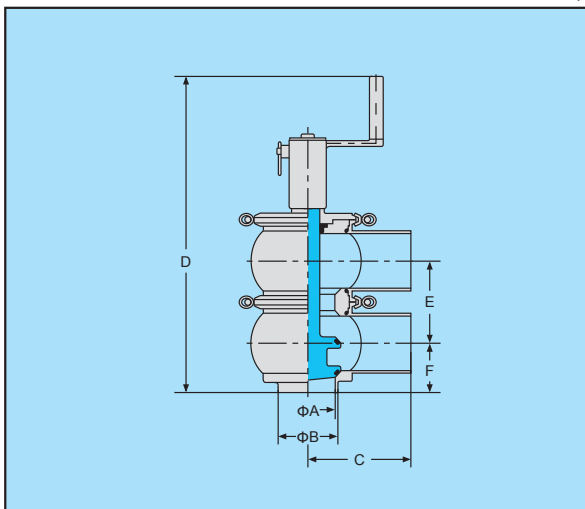
LL型手动换向阀 (短型)
型号type: IJSS-03
LL-Reversal Valve(short)

规格size	A	B	C	D	E	F	kg
1 ^s	22.4	25.4	60	230	47	28	
1.25 ^s	29	32	60	275	54	30.5	
1.5 ^s	35	38	60	293	59.5	33.5	
2 ^s	48	51	75	335	72	43	
2.5 ^s	59.5	63.5	100	370	90	50.5	
3 ^s	72.1	76.1	100	400	102	57	
4 ^s	97.6	101.6	125	450	128	71	

TL型手动换向阀 (短型)

型号type: IJSS-04

TL-Reversal Valve(short)

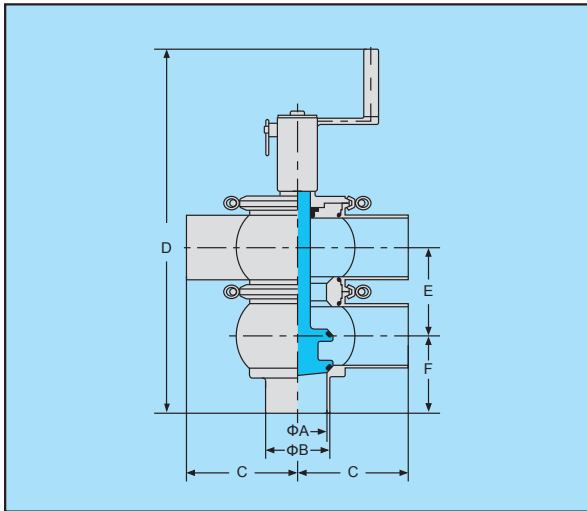

规格size	A	B	C	D	E	F	kg
1 ^s	22.4	25.4	60	230	47	28	
1.25 ^s	29	32	60	235	54	30.5	
1.5 ^s	35	38	60	240	59.5	33.5	
2 ^s	48	51	75	260	72	43	
2.5 ^s	59.5	63.5	100	280	90	50.5	
3 ^s	72.1	76.1	100	305	102	57	
4 ^s	97.6	101.6	125	360	128	71	

LT型手动换向阀 (短型)

型号type: IJSS-05

LT-Reversal Valve(short)

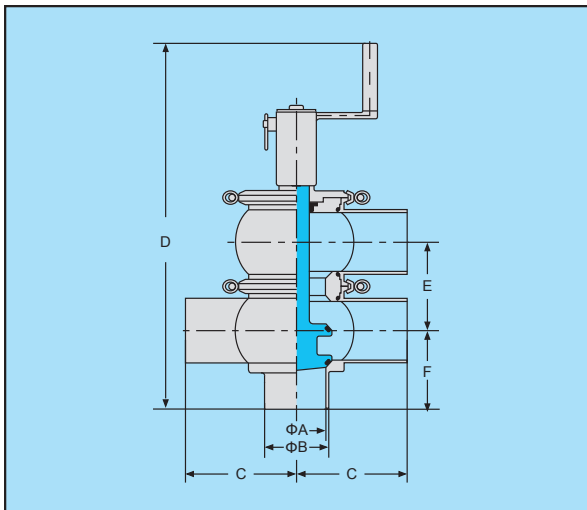

规格size	A	B	C	D	E	F	kg
1 ^s	22.4	25.4	60	230	47	28	
1.25 ^s	29	32	60	235	54	30.5	
1.5 ^s	35	38	60	240	59.5	33.5	
2 ^s	48	51	75	260	72	43	
2.5 ^s	59.5	63.5	100	280	90	50.5	
3 ^s	72.1	76.1	100	305	102	57	
4 ^s	97.6	101.6	125	360	128	71	

TT型手动换向阀 (短型)

型号type: IJSS-06

TT-Reversal Valve(short)

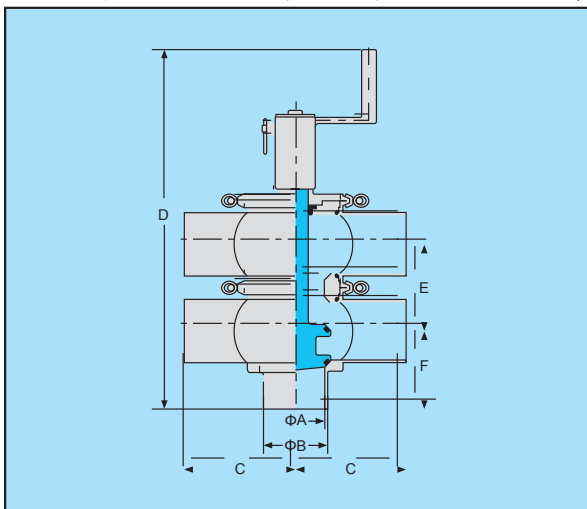

规格size	A	B	C	D	E	F	kg
1 ^s	22.4	25.4	60	230	47	28	
1.25 ^s	29	32	60	235	54	30.5	
1.5 ^s	35	38	60	240	59.5	33.5	
2 ^s	48	51	75	260	72	43	
2.5 ^s	59.5	63.5	100	280	90	50.5	
3 ^s	72.1	76.1	100	305	102	57	
4 ^s	97.6	101.6	125	360	128	71	

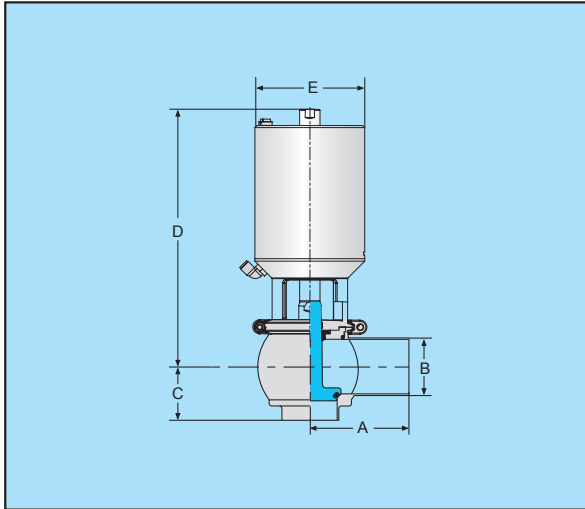
L型气动单座阀 (短型)
型号type: IJQS-01
L-Pneumatic Stop Valve(short)

规格size	A	B	C	D	E	F	kg
1 ^s	60	25.4	28	230	89		
1.25 ^s	60	32	30.5	235	89		
1.5 ^s	60	38	33.5	240	89		
2 ^s	75	51	43	260	109		
2.5 ^s	100	63.5	50.5	280	130		
3 ^s	100	76.1	57	305	130		
4 ^s	125	101.6	71	370	168		

注: 信号反馈装置为可以配置选项
 Signal feed back device can be chosen or not.

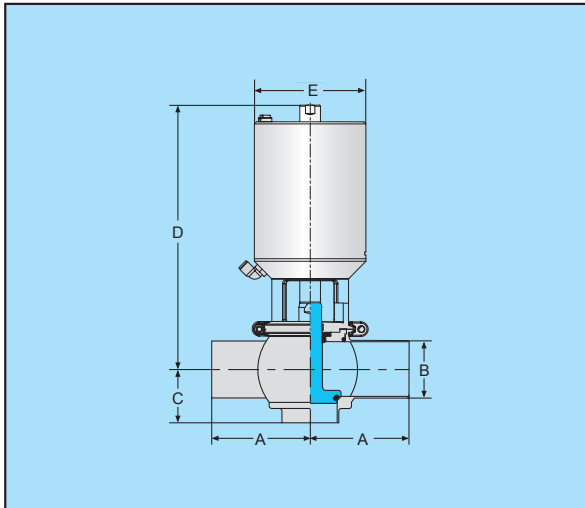
T型气动单座阀 (短型)
型号type: IJQS-02
T-Pneumatic Stop Valve(short)

规格size	A	B	C	D	E	F	kg
1 ^s	60	25.4	28	230	89		
1.25 ^s	60	32	30.5	235	89		
1.5 ^s	60	38	33.5	240	89		
2 ^s	75	51	43	260	109		
2.5 ^s	100	63.5	50.5	280	130		
3 ^s	100	76.1	57	305	130		
4 ^s	125	101.6	71	370	168		

注: 信号反馈装置为可以配置选项
 Signal feed back device can be chosen or not.

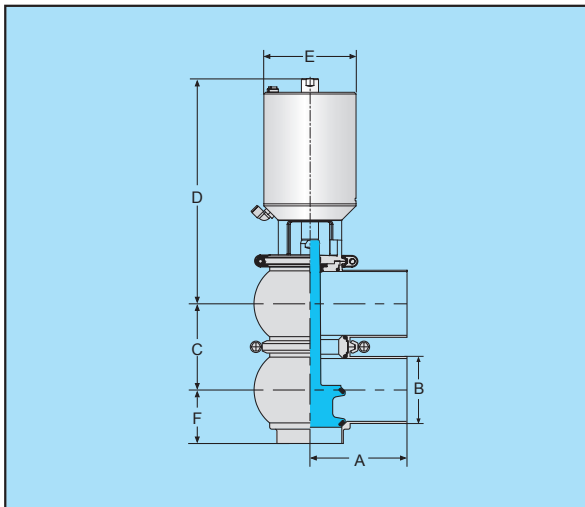
LL型气动换向阀 (短型)
型号type: IJQS-03
LL-Pneumatic Reversal Valve(short)

规格size	A	B	C	D	E	F	kg
1 ^s	60	25.4	47	230	89	28	
1.25 ^s	60	32	54	235	89	30.5	
1.5 ^s	60	38	59.5	240	89	33.5	
2 ^s	75	51	72	260	109	43	
2.5 ^s	100	63.5	90	280	130	50.5	
3 ^s	100	76.1	102	305	130	57	
4 ^s	125	101.6	128	370	168	71	

注: 信号反馈装置为可以配置选项
 Signal feed back device can be chosen or not.

TL型气动换向阀 (短型)

型号type: IJQS-04

TL-Pneumatic Reversal Valve(short)

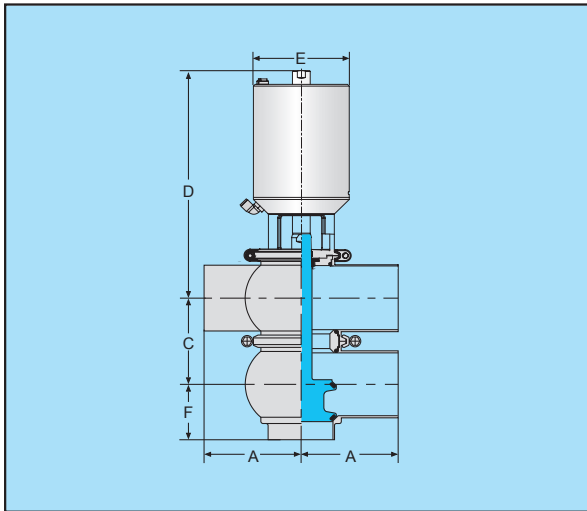

规格size	A	B	C	D	E	F	kg
1 ^s	60	25.4	47	230	89	28	
1.25 ^s	60	32	54	235	89	30.5	
1.5 ^s	60	38	59.5	240	89	33.5	
2 ^s	75	51	72	260	109	43	
2.5 ^s	100	63.5	90	280	130	50.5	
3 ^s	100	76.1	102	305	130	57	
4 ^s	125	101.6	128	370	168	71	

注: 信号反馈装置为可以配置选项
 Signal feed back device can be choosed or not.

LT型气动换向阀 (短型)

型号type: IJQS-05

LT-Pneumatic Reversal Valve(short)

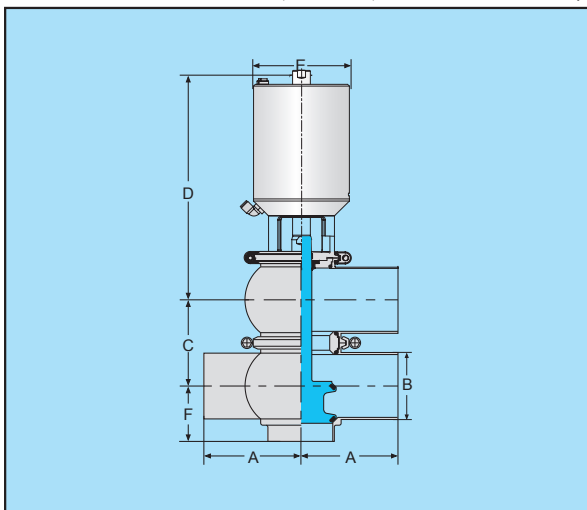

规格size	A	B	C	D	E	F	kg
1 ^s	60	25.4	47	230	89	28	
1.25 ^s	60	32	54	235	89	30.5	
1.5 ^s	60	38	59.5	240	89	33.5	
2 ^s	75	51	72	260	109	43	
2.5 ^s	100	63.5	90	280	130	50.5	
3 ^s	100	76.1	102	305	130	57	
4 ^s	125	101.6	128	370	168	71	

注: 信号反馈装置为可以配置选项
 Signal feed back device can be choosed or not.

TT型气动换向阀 (短型)

型号type: IJQS-06

TT-Pneumatic Reversal Valve(short)

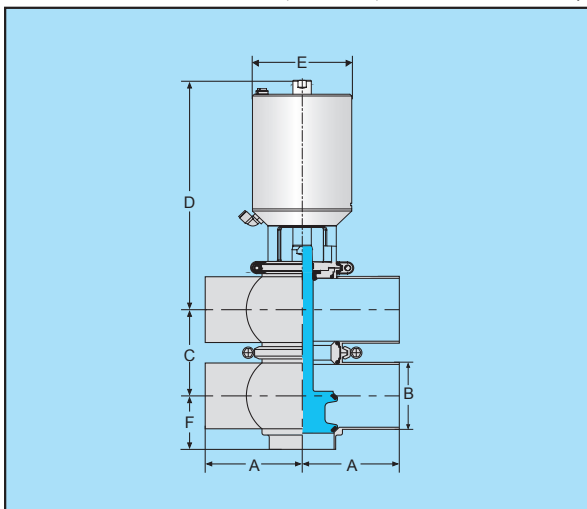

规格size	A	B	C	D	E	F	kg
1 ^s	60	25.4	47	230	89	28	
1.25 ^s	60	32	54	235	89	30.5	
1.5 ^s	60	38	59.5	240	89	33.5	
2 ^s	75	51	72	260	109	43	
2.5 ^s	100	63.5	90	280	130	50.5	
3 ^s	100	76.1	102	305	130	57	
4 ^s	125	101.6	128	370	168	71	

注: 信号反馈装置为可以配置选项
 Signal feed back device can be choosed or not.