

小巧型截止阀

应用

小型单座阀由于其卫生和灵活的设计而拥有广阔的应用空间，既作为两三个孔的截止阀，也可作为三五个孔的换向阀，这种类型的阀适合在食品、饮料、奶制品和制药工业中使用。

材质

- ◆ 产品与介质接触部分：304或316L
- ◆ 密封材料：标配EPDM另有硅胶、氟胶可选用

表面处理

- ◆ 外部：喷砂处理 $Ra \leq 1.6mm$
抛亚光 $Ra \leq 0.6mm$
- ◆ 内部：抛 光 $Ra \leq 0.6mm$ 以上

执行器使用压缩空气质量要求

- ◆ 压缩空气连接：空气管配备空气接头 R1/8"
- ◆ 最大颗粒尺寸：0.01mm
- ◆ 最大油含量：0.08ppm
- ◆ 露点：大气温度以下 $10^{\circ}C$ 或更低
- ◆ 最大水含量：7.5g/kg

Mini Check Valve

Application

As for the sanitary flexible design, mini single seat valve has wide application area. It can not only be used as check valve with two or three holes, but also can be used as reversal valve with has three or five holes. This kind of valve is suit to be used in food, beverage, dairy and pharmacy industries.



Material

- ◆ Material Contact Parts: 304 or 316L
- ◆ Sealing material: standard EPDM Silica gel, fluorine gel for option

Surface Treatment

- ◆ Outside: Sandblast $Ra \leq 1.6mm$
Sublight $Ra \leq 0.6mm$
- ◆ Inside: polish $Ra \leq 0.6mm$

Requirements For Compressed Air Quality That The Executor Needs

- ◆ Compressed air joint: air pipe equipped with air adapter R1/8"
- ◆ Max grain size: 0.01mm
- ◆ Max oil content: 0.08ppm
- ◆ Dew point: below $10^{\circ}C$ or less
- ◆ Max water content: 7.5g/kg

L型气动截止阀

型号type: DJX-01

L-Pneumatic Stop Valve

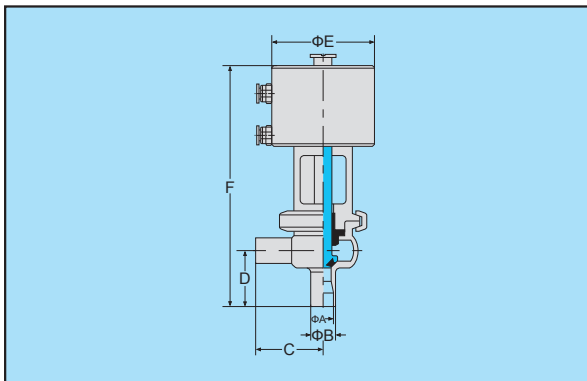

| 规格size | A | B | C | D | E | F | kg |
|--------|----|----|----|----|----|-----|----|
| DN15 | 15 | 18 | 40 | 40 | 75 | 175 | |
| 20 | 19 | 22 | 40 | 40 | 75 | 180 | |
| 25 | 25 | 28 | 60 | 60 | 75 | 185 | |

T型气动截止阀

型号type: DJX-02

T-Pneumatic Stop Valve

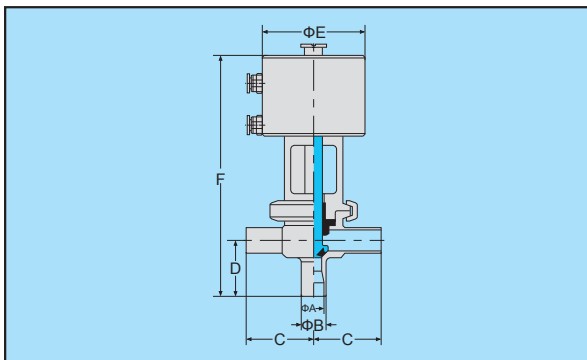

| 规格size | A | B | C | D | E | F | kg |
|--------|----|----|----|----|----|-----|----|
| DN15 | 15 | 18 | 40 | 40 | 75 | 175 | |
| 20 | 19 | 22 | 40 | 40 | 75 | 180 | |
| 25 | 25 | 28 | 60 | 60 | 75 | 185 | |

LL型气动截止阀

型号type: DJX-03

LL-Pneumatic Stop Valve

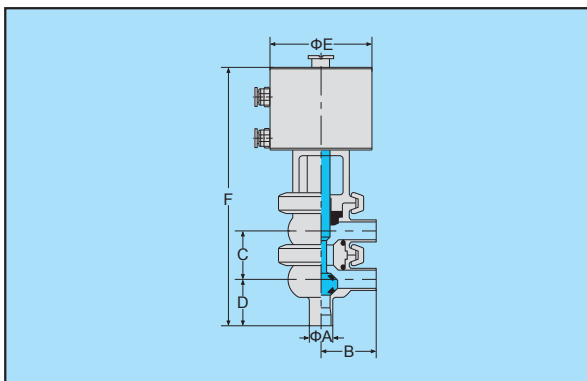

| 规格size | A | B | C | D | E | F | kg |
|--------|----|----|----|----|----|-----|----|
| DN15 | 18 | 40 | 37 | 40 | 75 | 215 | |
| 20 | 22 | 40 | 41 | 40 | 75 | 220 | |
| 25 | 28 | 60 | 47 | 60 | 75 | 235 | |

TT型气动截止阀

型号type: DJX-04

TT-Pneumatic Stop Valve

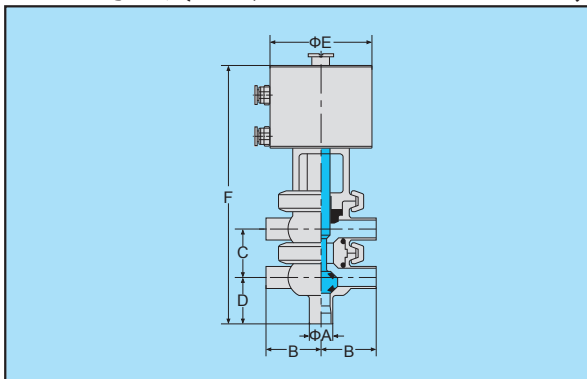

| 规格size | A | B | C | D | E | F | kg |
|--------|----|----|----|----|----|-----|----|
| DN15 | 18 | 40 | 37 | 40 | 75 | 215 | |
| 20 | 22 | 40 | 41 | 40 | 75 | 220 | |
| 25 | 28 | 60 | 47 | 60 | 75 | 235 | |

样本所示管径为DIN11850第一系列尺寸, 可按客户要求提供第二系列尺寸的产品。

The sizes marked in the handbook is DIN11850 NO.1 serie, No.2 serie products can also be offered by LYSF.